

My50 B

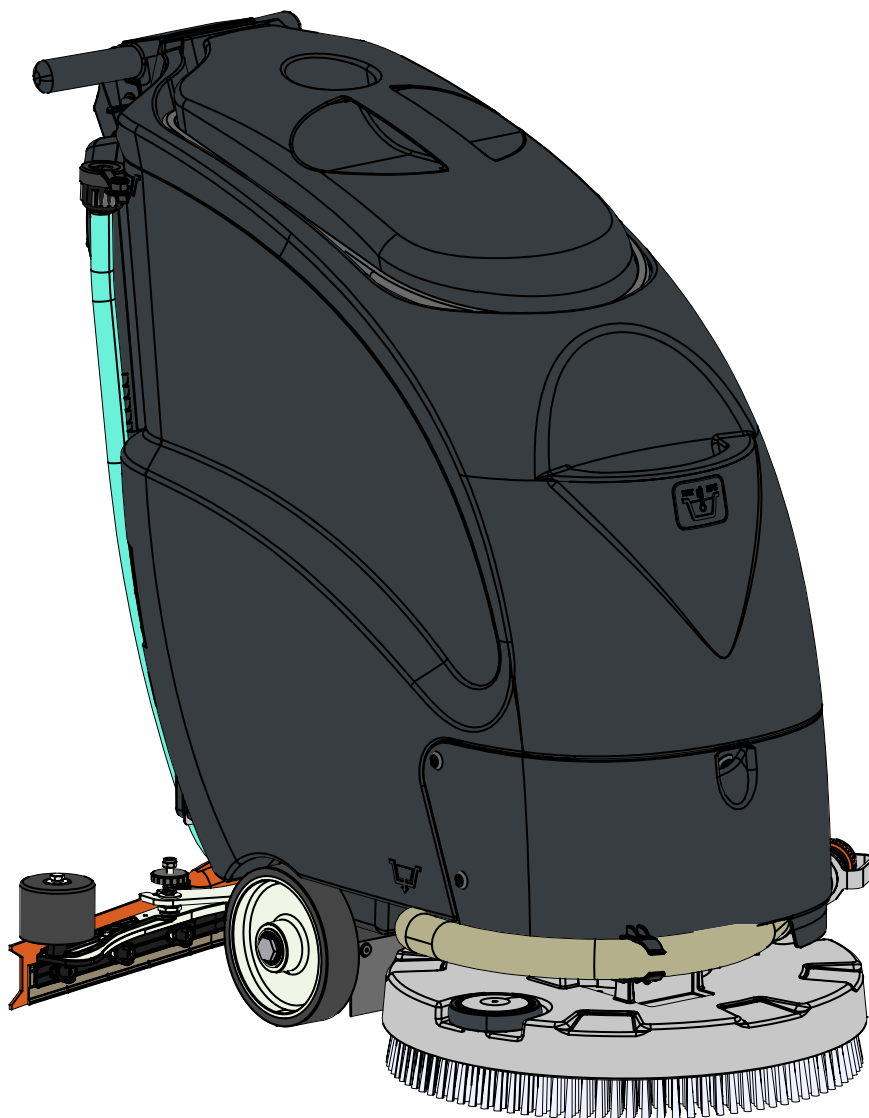

PROFESSIONAL SCRUBBING MACHINES

IT **CATALOGO RICAMBI**
EN **SPARE PARTS CATALOGUE**
FR **CATALOGUE DE PIECES DETACHEES**

DE **ERSATZKATALOG**
ES **CATALOGO PIEZAS DE REPUESTO**

 **FIMAP**[®]



SOMMARIO

SOMMARIO	3
GRUPPO BASAMENTO L=508mm L=20in.....	6
GRUPPO TERGIPAVIMENTO L=682,5mm L=26,75in.....	10
GRUPPO TERGIPAVIMENTO L=780mm L=30,75in.....	12
GRUPPO COMANDO TERGIPAVIMENTO	14
GRUPPO SERBATOI (VER. RAL7016)	18
GRUPPO IMPIANTO ELETTRICO	22
KIT CARICA BATTERIE (VER. CB)	26
GRUPPO ETICHETTE.....	28

SUMMARY

SUMMARY	3
BRUSH BASE ASSEMBLY L=508mm L=20in.....	6
SQUEEGEE ASSEMBLY L=682,5mm L=26,75in.....	10
SQUEEGEE ASSEMBLY L=780mm L=30,75in.....	12
SQUEEGEE CONTROL ASSEMBLY	14
ASSEMBLY TANKS (VER. RAL7016).....	18
ELECTRICAL SYSTEM GROUP	22
BATTERY CHARGER KIT (VER. CB).....	26
GROUP DECAL	28

SOMMAIRE

SOMMAIRE.....	3
GROUPE DE PLATEAU DES BROSSES L=508mm L=20in.....	6
GROUPE DE SUCEUR L=682,5mm L=26,75in.....	10
GROUPE DE SUCEUR L=780mm L=30,75in.....	12
GROUPE COMMANDE DE SUCEUR.....	14
GRUPO TANQUES (VER. RAL7016).....	18
GROUPE DE SYSTÈME ÉLECTRIQUE.....	22
KIT CHARGEUR DE BATTERIES (VER. CB).....	26
GROUPES DE ETIQUETTE	28

INHALTSANGABE

INHALTSANGABE.....	3
BÜRSTENGESTELL GRUPPE L=508mm L=20in.....	6
SAUGFUSSGRUPPE L=682,5mm L=26,75in.....	10
SAUGFUSSGRUPPE L=780mm L=30,75in.....	12
GRUPPE SAUGFUSSBETÄTIGUNG.....	14
GRUPPE TANKS (VER. RAL7016).....	18
ELEKTRISCHE SYSTEMGRUPPE	22
KIT LADEN BATTERIEN (VER. CB).....	26
GRUPPE SCHILD.....	28

ÍNDICE

ÍNDICE	3
GRUPO BANCADA CEPILLO L=508mm L=20in.....	6
GRUPO LIMPIADOR DE SUELO L=682,5mm L=26,75in.....	10
GRUPO LIMPIADOR DE SUELO L=780mm L=30,75in.....	12
GRUPO MANDO LIMPIAPAVIMENTOS	14
GROUPE DE RESERVOIRS (VER. RAL7016)	18
GRUPO SISTEMA ELECTRICO.....	22
KIT CARGADOR DE BATERÍAS (VER. CB)	26
GRUPOS ETIQUETA.....	28

IT - Le descrizioni contenute nella presente pubblicazione non si intendono impegnative. L'azienda pertanto, si riserva il diritto di apportare in qualunque momento, le eventuali modifiche ad organi, dettagli, forniture di accessori, che essa ritiene convenienti per un miglioramento o per qualsiasi esigenza di carattere costruttivo o commerciale.

La riproduzione anche parziale dei testi e dei disegni, contenuti nella presente pubblicazione, è vietata ai sensi di legge. L'azienda si riserva il diritto di apportare modifiche di carattere tecnico e/o di dotazione. Le immagini sono da intendersi di puro riferimento e non vincolanti in termini di design e dotazione.

INTRODUZIONE:

Il presente vuole essere da guida per l'ordinazione delle parti di ricambio ed è stato realizzato in modo da consentire una rapida identificazione della macchina in tutte le sue versioni e quindi una rapida visualizzazione dei pezzi che la compongono.

MODALITÀ DI ORDINAZIONE:

Per facilitare la ricerca di magazzino e la spedizione dei pezzi di ricambio, si pregano vivamente i Sig. Clienti di attenersi alle seguenti norme e specificare sempre :

Modello e numero di matricola della macchina;

Numero di posizione e numero di tavola dove sono rappresentati;

Codice di ordinazione e denominazione;

Quantità dei pezzi desiderati;

Indirizzo esatto e ragione sociale del Committente, completo con l'eventuale recapito per la consegna della merce;

Mezzo di spedizione desiderato. (Nel caso questa voce non sia specificata la Ditta Costruttrice si riserva di usare a sua discrezione il mezzo più opportuno).

EN - The contained descriptions in the present publication are not binding. The Manufacturer therefore reserves itself the right to bring in whatever moment possible organs changes, details or supplies of accessories, that it holds convenient for an improvement, or for any demand of constructive or commercial character. The partial reproduction of the texts and diagrammes contained in the present catalog, is forbidden by law. The Manufacturer reserves itself the right to bring changes of technical character and/or of endowment. The images are meant of pure reference and not binding in terms of design and endowment.

INTRODUCTION:

This catalogue is intended to serve as a guide for the ordering of spare parts and is designed to facilitate rapid identification of the machine in all its versions and to rapid location of its component parts.

HOW TO ORDER:

For the purpose of simplifying stock searching and the delivery of spare parts, we would ask our customers to observe the following standard procedures, at all times specifying:

The model and part number of the machine;

The position number and the number of the table of chart in which the parts appear;

Ordering code and part name;

Quantity of parts required;

Precise address and company status of the purchaser placing the order, complete with address for delivery of the goods;

Shipping means required.

FR - Les descriptions contenu dans la présente publication ne s'entendent pas contraignant. Le Fabriquant donc, il se réserve le droit d'apporter dans n'importe quel moment, les modifications éventuelles à organes, détails, fournitures d'accessoires, qu'elle croit convenables pour une amélioration ou pour n'importe quel exigence de caractère constructif ou commercial.

La reproduction partielle aussi des textes et des dessins, contenu dans le présent catalogue, elle est prohibée aux termes de la loi.

Le Fabriquant se réserve le droit d'apporter modifications de caractère technique et/ou de dotation. Les images sont à s'entendre en référence pure et pas contraignants en termes de design et dotation.

INTRODUCTION:

Le présent catalogue a pour but de guider l'utilisateur dans les commandes de pièces détachées. Il a été réalisé pour faciliter une identification rapide de la machine dans toutes ses versions et permet ainsi un repérage rapide de ses composants.

COMMENT PASSER COMMANDE:

Afin de simplifier la recherche dans le magasin et l'expédition des pièces de rechange, nous prions notre clientèle de respecter la procédure suivante en indiquant toujours:

Le modèle et numéro de la machine;

Le numéro de la position et numéro du tableau sur lequel figure la pièce;

La référence et la dénomination;

La quantité des pièces demandées;

L'adresse exacte et la raison sociale de l'acheteur qui passe la commande, en indiquant l'adresse de livraison;

Le moyen de transport désiré (dans le cas où ceci n'est pas précisé l'expéditeur se réserve le droit de choisir le transporteur).

DE - Die Beschreibungen, welche in der vorliegenden Veröffentlichung vorhanden sind, sind nicht verpflichtend. Die Firma behält sich das Recht vor jederzeit eventuelle Modifikationen an wesentlichen Baugruppen, Details und Zubehör-Teilen durchzuführen, wenn dies für vorteilhaft bewertet wird und zu einer Verbesserung führt oder aufgrund von konstruktiven oder kommerziellen Anforderungen. Die Vervielfältigung, auch wenn es sich nur um Text-Auszügen oder Abbildungen handelt, der vorliegenden Bedienungsanleitung ist entsprechend dem Gesetz untersagt. Die Firma behält sich das Recht vor technische Eigenschaften und Ausstattungen zu modifizieren. Die Abbildungen sind zum Verständnis und dienen als Bezug sind nicht bindend in Bezug auf Design und Ausstattung.

EINLEITUNG:

Der vorliegende Katalog versteht sich als Führer für Ersatzteile und soll eine rasche Identifikation der Maschine in all ihren Ausführungen ermöglichen und daher ein sofortiges Erkennen der Teile, aus denen sie besteht.

BESTELLVORSCHLAG:

Um ein Auffinden im Lager und den Versand der Ersatzteile zu erleichtern, werden die Kunden ersucht, sich an folgende Normen zu halten und immer folgendes anzugeben:

Modell- und Gerätenummer;

Positions- und Tafelnummer, wo sie dargestellt sind;

Bestellnummer und Handelsbezeichnung;

Menge der gewünschten Teile;

Genauere Adresse und Firmennamen des Auftraggebers, gemeinsam der ev. Anschrift für die Zusendung der Ware;

Die gewünschte Versandart (falls nicht angegeben, behält sich der Lieferant das Recht vor, die günstigste Art zu wählen)

ES - Las descripciones contenidas en la presente publicación no son empeñativas. La Empresa por lo tanto se reserva el derecho de aportar en cualquier momento, eventuales modificaciones a órganos, detalles, suministros de accesorios, que ella crea conveniente para una mejoría o por cualquier exigencia de carácter constructivo o comercial. La reproducción parcial de los textos y los diseños, contenidos en el presente catálogo, está prohibida por la ley. La Empresa se reserva el derecho a aportar modificaciones de carácter técnico e/o de dotación. Las imágenes son de pura referencia y no vinculantes en términos de diseño y dotación.

INTRODUCCIÓN:

Ese catálogo quiere servir cómo guía para pedir las piezas de repuesto y se ha realizado de manera de consentir una rápida identificación de la máquina en todas sus versiones y por consiguiente una rápida individuación de las piezas que la componen.

MODALIDADES DE LOS PEDIDOS:

Para la búsqueda en el almacén y el envío de las piezas de repuesto, se ruega encarecidamente a los Sres. Clientes de seguir las reglas siguientes y de especificar siempre:

El modelo y el número de matrícula de la máquina;

El número de posición y el número de la tabla donde son representadas;

El código de pedido y la denominación;

El número de piezas que se desean;

Las señas exactas y la razón social del Comitente, indicando también las señas eventuales para la entrega de la mercancía;

El medio de envío que se desea. (En caso de que ese dato no se haya especificado, la Empresa Constructora se reserva el derecho de utilizar a su elección el medio más adecuado.

AGGIORNAMENTI DALLA VERSIONE PRECEDENTE:

→ = Documento valido dalla matricola.

← = Documento annullato dalla matricola.

UPDATES FROM THE PREVIOUS VERSION:

→ = This document is valid since the serial number.

← = This document is valid till the serial number.

MISE À JOUR DE LA VERSION PRÉCÉDENTE:

→ = Document valable à partir du numéro de série.

← = Document annulé par le numéro de série.

UPDATES FROM THE PREVIOUS VERSION:

→ = This document is valid since the serial number.

← = This document is valid till the serial number.

ACTUALIZACIÓN DE LA VERSIÓN ANTERIOR:

→ = Documento válido desde la matrícula n°.

← = Documento válido hasta la matrícula n°.

	PAG.	N. DOC.	VER.	SERIAL NUMBER
←	10	10028603	AC	
←	14	10028604	AA	
←	26	10028601	AC	
→	18	10091091	AA	
←	34	10028625	AB	
←	38	10028627	AB	
←	46	10028638	AC	
←	48	10028649	AA	
←	50	10028650	AA	

CR-01/08 GRUPPO BASAMENTO L=508mm L=20in

BRUSHES BASE ASSEMBLY
GROUPE PLATEAU DES BROSSES
GRUPE BÜRSTENGESTELL
GRUPO BANCADA CEPILLOS

01/08

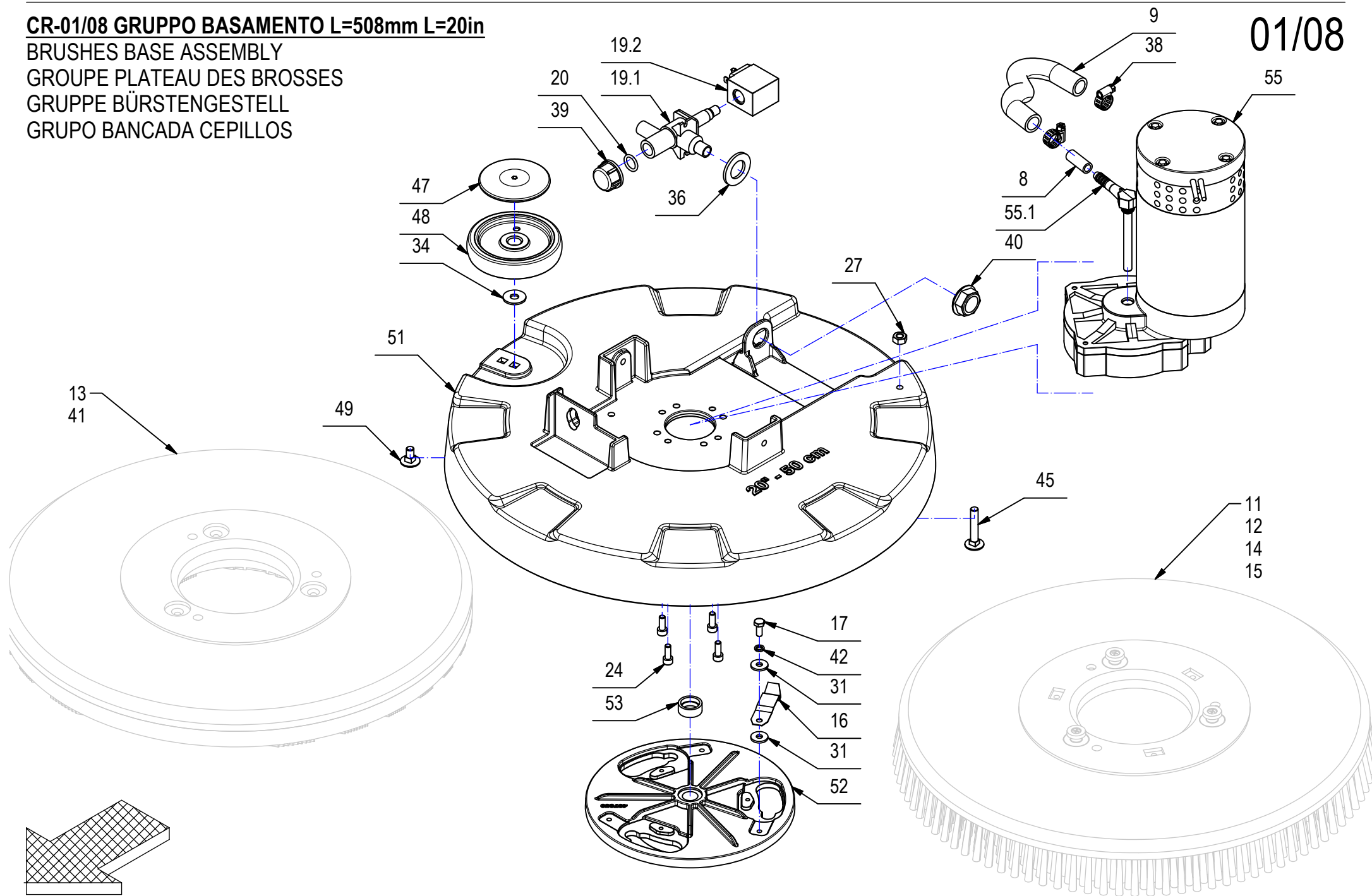

CR-01/08 GRUPPO BASAMENTO L=508mm L=20in**01/08**

POS.	CODICE	QTÀ	DESCRIZIONE	DENOMINATION	DESCRIPTION	BENENNUNG	DESCRIPCION
1	204233	1	PIASTRA MOTORE	PLAQUE	PLAQUE	BEFESTIGUNGSAUFLAGE	PLACA
2	205112	1	DISTANZIALE D=18 d=6,5 S=4 AVP	WASHER	RONDELLE	UNTERLAGSCHEIBE	ARANDELA
3	209845	1	MOLLA COMP. 20x 2x4 x58	SPRING	RESSORT	FEDER	RESORTE
4	210541	2	PORTAGOMMA DIRITTO G 1-2" MASCHIO D=13	CONNECTOR	RACCORD	SCHLAUCHANSCHLUSS	EMPALME TUBO DE GOMA
5	212616	1	FILTRO 1/2" F-F	FILTER ASSEMBLY	FILTRE COMPLET	FILTER KOMPLETT	FILTRO COMPLETO
6	219723	1	PREM. MOT. ASP. 24V 310W H950 PERIF. 2ST	SUCTION MOTOR	MOTEUR D'ASPIRATION	SAUGMOTOR	MOTOR DE ASPIRACION
6.1	409660	2	CONNETTORE 30A ROSSO M/F	CONNECTOR	CONNECTEUR	STECKER	CONECTOR
6.2	409661	2	CONTATTO CONNETT. ANDERS. 30A	CONTACT	CONTACT	KONTAKT	CONTACTO
6.3	410274	2	FASCETTA PLASTICA 2.5x98	CLAMP	COLLIER	BRIDE	ABRAZADERA
6.4	430959	1	MOT. ASP. 24V 410W H1200 2ST S711267	SUCTION MOTOR	MOTEUR D'ASPIRATION	SAUGMOTOR	MOTOR DE ASPIRACION
7	220821	2	PERNO SUPP. MOT. L=120 CH=13 M8/M6	PIN	AXE	BOLZEN	PERNO
8	221379	1	TUBO VITREO D=12 d=8 L=30	PIPE	TUBE	ROHR	TUBO
9	223181	1	GUAINA FX15N L=170	PIPE	TUBE	ROHR	TUBO
10	224100	1	TUBO SPIRALATO D=17 d=12 L=90	PIPE	TUBE	ROHR	TUBO
11	404653	1	SPAZZOLA 20" D=508 -FUSTO D=495 -PPL 0,9	BRUSH	BROSSE	BÜRSTE	CEPILLO
12	404654	1	SPAZZOLA 20" D=508 -FUSTO D=495 -PPL 0,3	BRUSH	BROSSE	BÜRSTE	CEPILLO
13	405527	1	DISCO TRASCINATORE D=497 - 20" C-LOCK	PAD HOLDER	DISQUE ENTRAÎNEUR	TREIBTELLERS	DISCO DE ARRASTRE
14	405631	1	SPAZZOLA 20" D=508 -FUSTO D=495 -PPL 0,6	BRUSH	BROSSE	BÜRSTE	CEPILLO
15	405632	1	SPAZZOLA 20" D=508 -FUSTO D=495 -TYNEX 1	BRUSH	BROSSE	BÜRSTE	CEPILLO
16	407598	1	MOLLA BLOCCAGGIO SPAZZOLE	SPRING	RESSORT	FEDER	RESORTE
17	407662	1	VITE M6x14 TE UNI 5739 A2	SCREW	VIS	SCHRAUBE	TORNILLO
18	407666	1	VITE M6x20 TE UNI 5739 ZINC	SCREW	VIS	SCHRAUBE	TORNILLO
19	407887	1	ELETTRORVALVOLA COMPLETA 24V 1/2" ACL 3	SOLENOID VALVE	ELECTROVANNE	MAGNETVENTIL	ELECTROVALVULA
19.1	407859	1	CORPO ELETTRORVALVOLA 1/2- V.24/36 (ACL)	SOLENOID VALVE BODY	CORPS D#ELECTROVANNE	KÖRPER MAGNETVENTIL	CUERPO ELECTROVALVULA
19.2	407866	1	BOBINA 24V 1/2 (PER ACL 407887)	COIL	BOBINE	SPULE	BOBINA
20	408595	1	GUARNIZIONE OR 3056	GASKET	JOINT	DICHTUNG	JUNTA
21	408677	2	VITE 8X30 UNI 5739 A2 TE	SCREW	VIS	SCHRAUBE	TORNILLO
22	408692	1	VITE M8x50 TE UNI 5739 ZINC	SCREW	VIS	SCHRAUBE	TORNILLO
23	408796	2	VITE M6x20 TCEI UNI 5931 ZINC	SCREW	VIS	SCHRAUBE	TORNILLO
24	408808	4	VITE M6x16 TCEI UNI 5931 ZINC	SCREW	VIS	SCHRAUBE	TORNILLO
25	408883	4	VITE D.4,8x13 TCTC AUTOF. NICH UNI 6954	SCREW	VIS	SCHRAUBE	TORNILLO
26	409046	1	DADO M8x6,5 UNI 5588 ZINC	NUT	ECROU	MUTTER	TUERCA
27	409049	1	DADO M8x6,5 UNI5588 A2	NUT	ECROU	MUTTER	TUERCA
28	409082	2	DADO M6x6 AUTOBL UNI 7474 ZINC	LOCK NUT	ECROU AUTOFREINES	SICHERUNGSMUTTER	TUERCA AUTOBLOCANTE
29	409156	2	ROSETTA 6x12x1,6 UNI 6592 ZINC	WASHER	RONDELLE	UNTERLAGSCHEIBE	ARANDELA
30	409160	2	ROSETTA 6x18x1,5 UNI 6593 ZINC	WASHER	RONDELLE	UNTERLAGSCHEIBE	ARANDELA
31	409161	2	ROSETTA 6,6x18x2 UNI 6593 A2	WASHER	RONDELLE	SCHEIBE	ARANDELA
32	409162	1	ROSETTA 6,5x24x2 UNI 6593 ZINC	WASHER	RONDELLE	UNTERLAGSCHEIBE	ARANDELA

CR-01/08 GRUPPO BASAMENTO L=508mm L=20in

BRUSHES BASE ASSEMBLY
 GROUPE PLATEAU DES BROSSES
 GRUPPE BÜRSTENGESTELL
 GRUPO BANCADA CEPILLOS

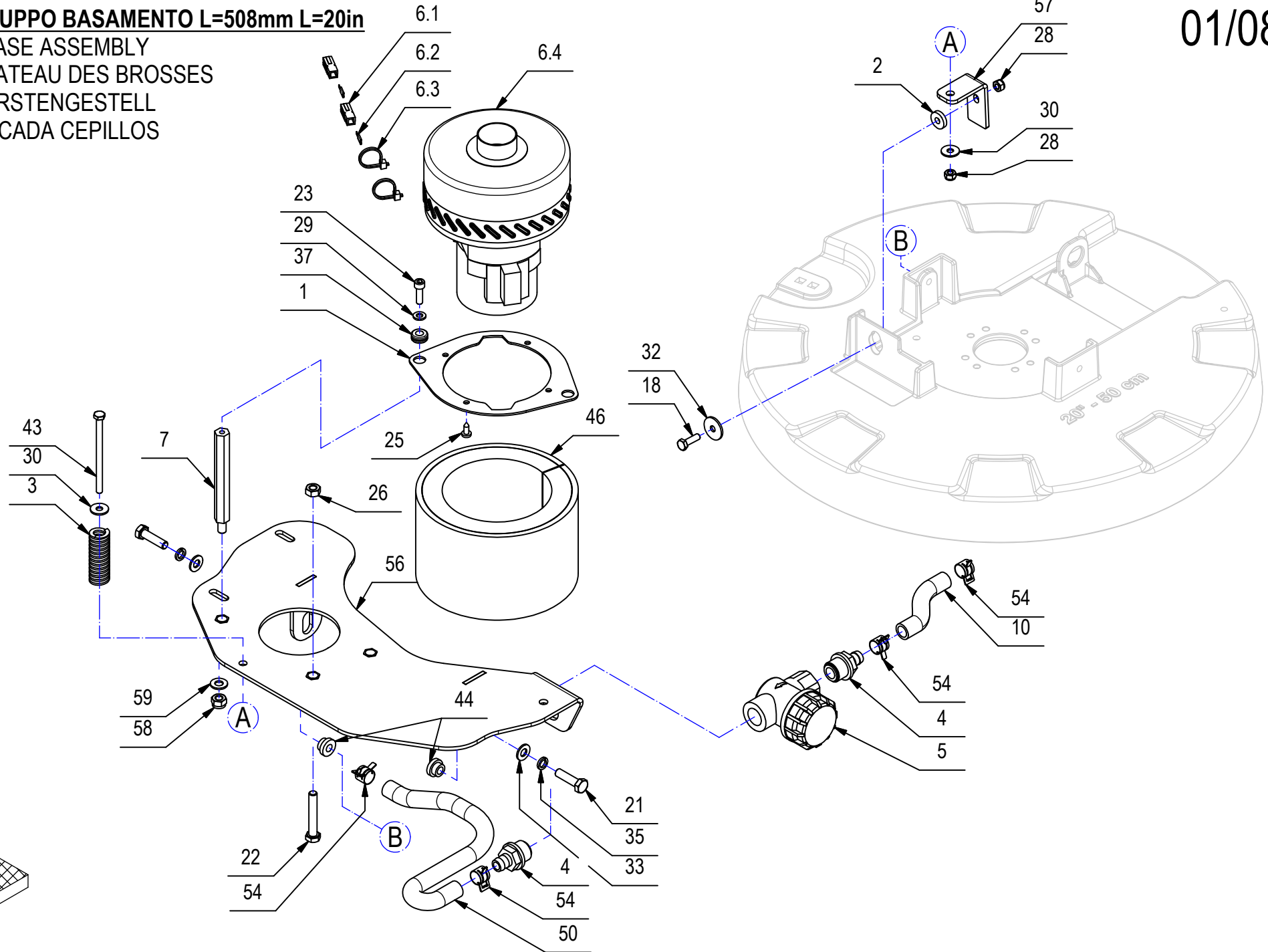

CR-01/08 GRUPPO BASAMENTO L=508mm L=20in**01/08**

POS.	CODICE	QTÀ	DESCRIZIONE	DENOMINATION	DESCRIPTION	BENENNUNG	DESCRIPCION
33	409177	2	ROSETTA 8x17x1.6 UNI 6592 A2	WASHER	RONDELLE	SCHEIBE	ARANDELA
34	409185	1	ROSETTA 9x24x2,5 UNI 6593 A2	WASHER	RONDELLE	UNTERLEGSSCHEIBE	ARANDELA
35	409187	2	ROSETTA GROWER 8x13x2,2 A2	WASHER	RONDELLE	UNTERLAGSCHEIBE	ARANDELA
36	409230	1	ROSETTA 21x37x3 UNI 6592 ZINC	WASHER	RONDELLE	UNTERLAGSCHEIBE	ARANDELA
37	409810	2	PASSAFILO DIAM. 8x12x1.5	FAIRLEAD	PASSE-CABLE	KABELDURCHGANG	GUIACABLE
38	410292	2	FASCETTA A VITE 11/17 ABA	CLAMP	COLLIER	BRIDE	ABRAZADERA
39	410409	1	TAPPO FEMMINA 1/2" - PLASTICA	CAP	CAPUCHON	KAPPE	TAPON
40	410442	1	GHIERA 1/2"	RING NUT	EMBOUT	STOPMUTTER	TUERCA ANULAR
41	410575	1	CENTER LOCK H=20 A VITE VERDE	CENTER LOCK	CENTER LOCK	CENTER LOCK	CENTER LOCK
42	415945	1	ROSETTA M6 UNI 1751 INOX GROWER	WASHER	RONDELLE	UNTERLAGSCHEIBE	ARANDELA
43	422078	1	VITE M6X90 TE UNI5737 DIN931 ZINC	SCREW	VIS	SCHRAUBE	TORNILLO
44	422120	2	BOCCOLA D=18-13 d=8 S=9,5 OT54	BUSHING	BAGUE	BUCHSE	CASQUILLO
45	428807	1	VITE M8x45 TTQST UNI 5732 INOX	SCREW	VIS	SCHRAUBE	TORNILLO
46	433704	1	FONOASSORBENTE SP= 6+20 L=410 H=100	DEADENING	ISOLANT PHONIQUE	SCHALLDICHTUNG	FONOABSORBENTE
47	436119	1	BOCCOLA COPERTURA RUOTINA BASAMENTO	BUSHING	BAGUE	BUCHSE	CASQUILLO
48	436120	1	RUOTINA PARACOLPI BASAMENTO D=100 H=20	BUMPER	BUTEE	PUFFER	PARACHOQUES
49	436341	1	VITE M8x16 TTQST - UNI 5732 - A2	SCREW	VIS	SCHRAUBE	TORNILLO
50	437147	1	TUBO VITREO SPIR. D=17 d=12 L=300	PIPE	TUBE	ROHR	TUBO
51	437855	1	BASAMENTO	BRUSH BASE	EMBASE DE BROSE	BÜRSTENGESTELL	BANCADA CEPILLO
52	437859	1	FLANGIA SPAZZOLA	FLANGE	FLASQUE	FLANSCH	BRIDA
53	438110	1	DISTANZIALE D=25 d=18,1-20 S=10 AISI 303	SPACER	ENTRETOISE	DISTANZHÜLSE	DISTANCIADOR
54	438261	4	FASCETTA METALLICA FBS 17/12	CLAMP	COLLIER	BRIDE	ABRAZADERA
55	438300	1	MOTORID. 24V 500W 140RPM ALBERO FIL. SX	GEARED MOTOR ASSEMBLY	MOTO-REDUCTEUR COMPLET	GETRIEBEMOTOR KOMPLETT	MOTORREDUCTOR COMPLETO
55.1	423060	1	PORTAGOMMA ESAGONALE FILET. G1/4 MASCHIO	FITTING	RACCORD	VERSCHRAUBUNG	RACOR
56	439800	1	STAFFA SUPPORTO BASAMENTO	BRUSH BASE SUPPORT	SUPPORT EMBASE DE BROSSE	HALTERUNG BÜRSTENGESTELL	SOPORTE BANCADA CEPILLO
57	439801	1	STAFFA MOLLA BASAMENTO	SUPPORT	SUPPORT	HALTERUNG	SOPORTE
58	409085	3	DADO M8x8.5 AUTOBL. UNI 7474 ZINC	LOCK NUT	ECROU AUTOFREINES	SICHERUNGSMUTTER	TUERCA AUTOBLOCANTE
59	409175	3	ROSETTA 8x17x1,6 UNI 6592 ZINC.	WASHER	RONDELLE	UNTERLAGSCHEIBE	ARANDELA

CR-03 PREM. TERGIPAVIMENTO L=682,5mm L=26,75in

SQUEEGEE ASSEMBLY

ENSEMBLE DE SUCEUR

SAUGFUSSGRUPPE

GRUPO LIMPIADOR DE SUELO

03

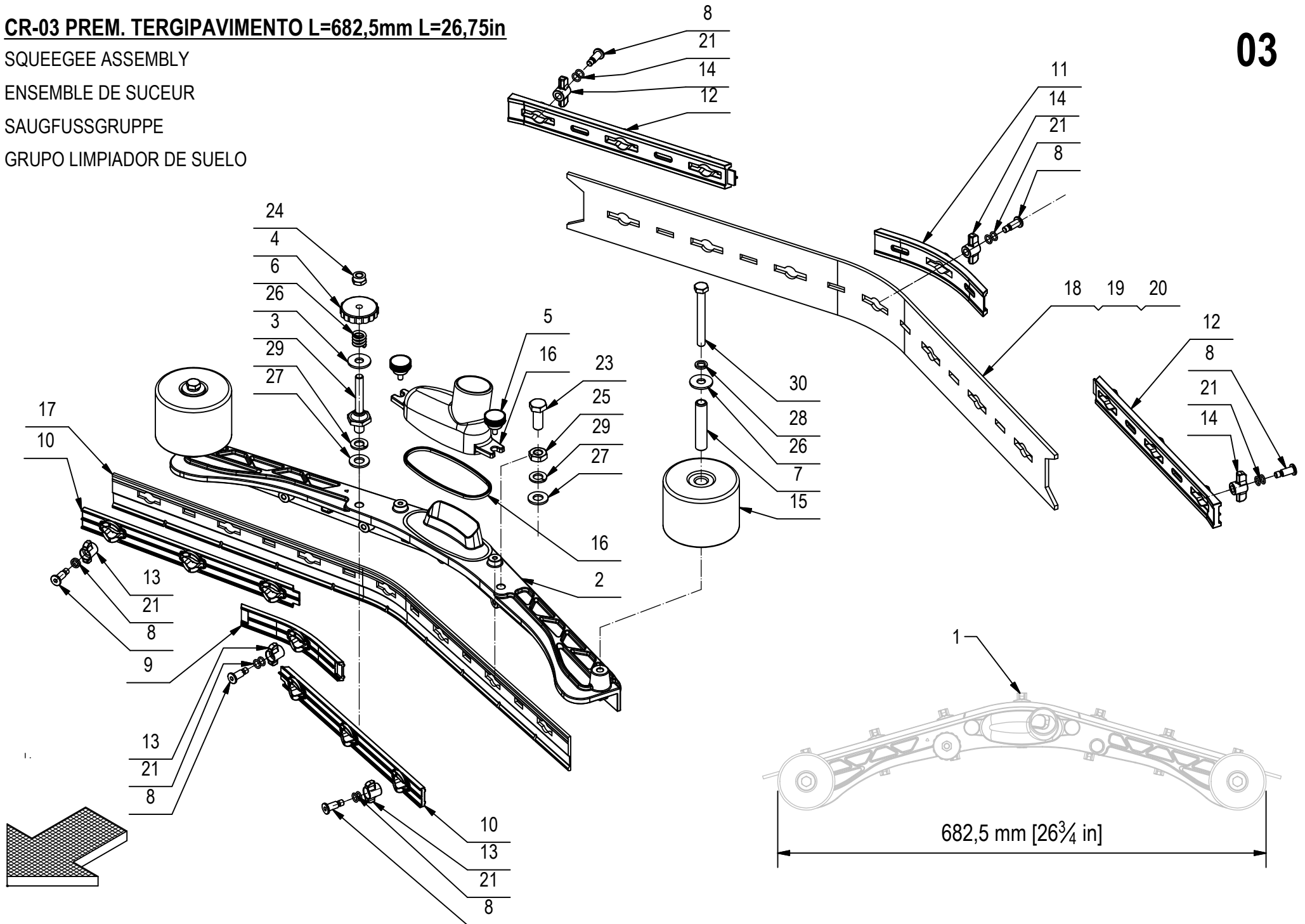

CR-03 PREM. TERGIPAVIMENTO L=682,5mm L=26,75in**03**

POS.	CODICE	QTÀ	DESCRIZIONE	DENOMINATION	DESCRIPTION	BENENNUNG	DESCRIPCION
1	220615	1	PREM. TERGIPAVIMENTO L=680	SQUEEGEE ASSEMBLY	SUCEUR COMPLETE	SAUGFUSS KOMPLETT	LIMPIAPAVIMENTOS COMPLETO
2	430940	1	CORPO TERGIPAVIMENTO 2010 L=638	SQUEEGEE BODY	CORPS DE SUCEUR	SAUGFUSSKÖRPER	CUERPO LIMPIAPAVIMENTOS
3	219372	1	COLONNETTA SGANCIO M10-CH22 - M8 (28-45)	STUD BOLT	TIGE	GEWINDEBOLZEN	PRISIONERO
4	400112	1	VOLANTINO LOBATO PASSANTE V/40/PS M8	HANDWHEEL	VOLANT	HANDGRIFF	RUEDA DE MANIOBRA
5	435330	2	VOLANTINO ZIGRINATO ZPX/22 M5x10 6331400	KNOB	POMMEAU	RENDELSCHRAUBE	POMO
6	408098	1	MOLLA COMPR. 14,5x15x2,5 COLON. TERGIP.	SPRING	RESSORT	FEDER	RESORTE
7	411765	2	BOCCOLA D=12 d=8,2 S=58,5 OT63	BUSHING	BAGUE	BUCHSE	CASQUILLO
8	430903	14	PERNO MANOPOLINA D=11,8 d=7 M=6 H=22	PIN	AXE	BOLZEN	PERNO
9	430944	1	PREMIGOMMA ANTERIORE CENTRALE TERGI 2010	FRONT BLADE	PLAQUETTE AVANT	VORDERER LEISTE	LISTON DELANTERA
10	430945	2	PREMIGOMMA ANTERIORE L=638 TERGI 2010	FRONT BLADE	PLAQUETTE AVANT	VORDERER LEISTE	LISTON DELANTERA
11	430949	1	PREMIGOMMA POSTERIORE CENTRALE TERGI2010	REAR BLADE	PLAQUETTE ARRIERE	HINTERER LEISTE	LISTON TRASERA
12	430950	2	PREMIGOMMA POSTERIORE L=638 TERGI 2010	REAR BLADE	PLAQUETTE ARRIERE	HINTERER LEISTE	LISTON TRASERA
13	430954	7	GALLETTO CHIUSURA ANTERIORE TERGI 2010	WING NUT	PAPILLON	FLÜGELSCHRAUBE	POMO
14	430955	7	GALLETTO CHIUSURA POSTERIORE TERGI 2010	WING NUT	PAPILLON	FLÜGELSCHRAUBE	POMO
15	430956	2	RUOTA PARACOLPI D=80 d=12 H=60	BUMPER WHEEL	ROUE BUTEE	PUFFER RAD	RUEDA PARACHOQUES
16	430957	1	BOCCHETTA DRITTA D=40 + GUARN. TERGI2010	OPENING	BUSE	ÖFFNUNG	BOQUILLA
17	219374	1	GOMMA ANT. POLIURETANO H=45 L=690 S=4	FRONT RUBBER	BAVETTE AVANT	VORDERER SAUGGUMMI	GOMA DELANTERA
18	430968	1	GOMMA POST. POLIURETANO H=70 L=750 S=5	REAR RUBBER	BAVETTE ARRIERE	HINTERER SAUGGUMMI	GOMA TRASERA
19	431024	1	GOMMA POST. 33 SHORE H=70 L=750 S=4	REAR RUBBER	BAVETTE ARRIERE	HINTERER SAUGGUMMI	GOMA TRASERA
20	431026	1	GOMMA POST. LATEX H=70 L=750 S=5	REAR RUBBER	BAVETTE ARRIERE	HINTERER SAUGGUMMI	GOMA TRASERA
21	431633	28	O-RING 7x1,5 NBR 70 SHORE	O-RING	JOINT	O-RING	JUNTA ANULAR
23	408741	1	VITE M10x25 TE UNI 5739 A2	SCREW	VIS	SCHRAUBE	TORNILLO
24	409087	1	DADO M8 AUTOBL. UNI 7474 INOX BASSO	LOCK NUT	ECROU AUTOFREINES	SICHERUNGSMUTTER	TUERCA AUTOBLOCANTE
25	415903	1	DADO M10 UNI5589 A2	NUT	ECROU	MUTTER	TUERCA
26	409185	3	ROSETTA 9x24x2,5 UNI 6593 A2	WASHER	RONDELLE	UNTERLEGSCHIEBE	ARANDELA
27	409192	2	ROSETTA 10x21x2 UNI 6592 A2	WASHER	RONDELLE	UNTERLAGSCHIEBE	ARANDELA
28	409187	2	ROSETTA GROWER 8x13x2,2 A2	WASHER	RONDELLE	UNTERLAGSCHIEBE	ARANDELA
29	409200	2	ROSETTA GROWER 10x2,5x2,5 A2	LOCK WASHER	RONDELLE FREIN	ZAHNSCHIEBE	ARANDELLA DENTADA
30	408696	2	VITE M8X70 TE INOX UNI 5739.	SCREW	VIS	SCHRAUBE	TORNILLO

CR-03 PREM. TERGIPAVIMENTO L=780mm L=30,75in

SQUEEGEE ASSEMBLY

SUCEUR COMPLET

SAUGFUSS KOMPLETT

LIMPIAPAVIMENTOS COMPLETO

03

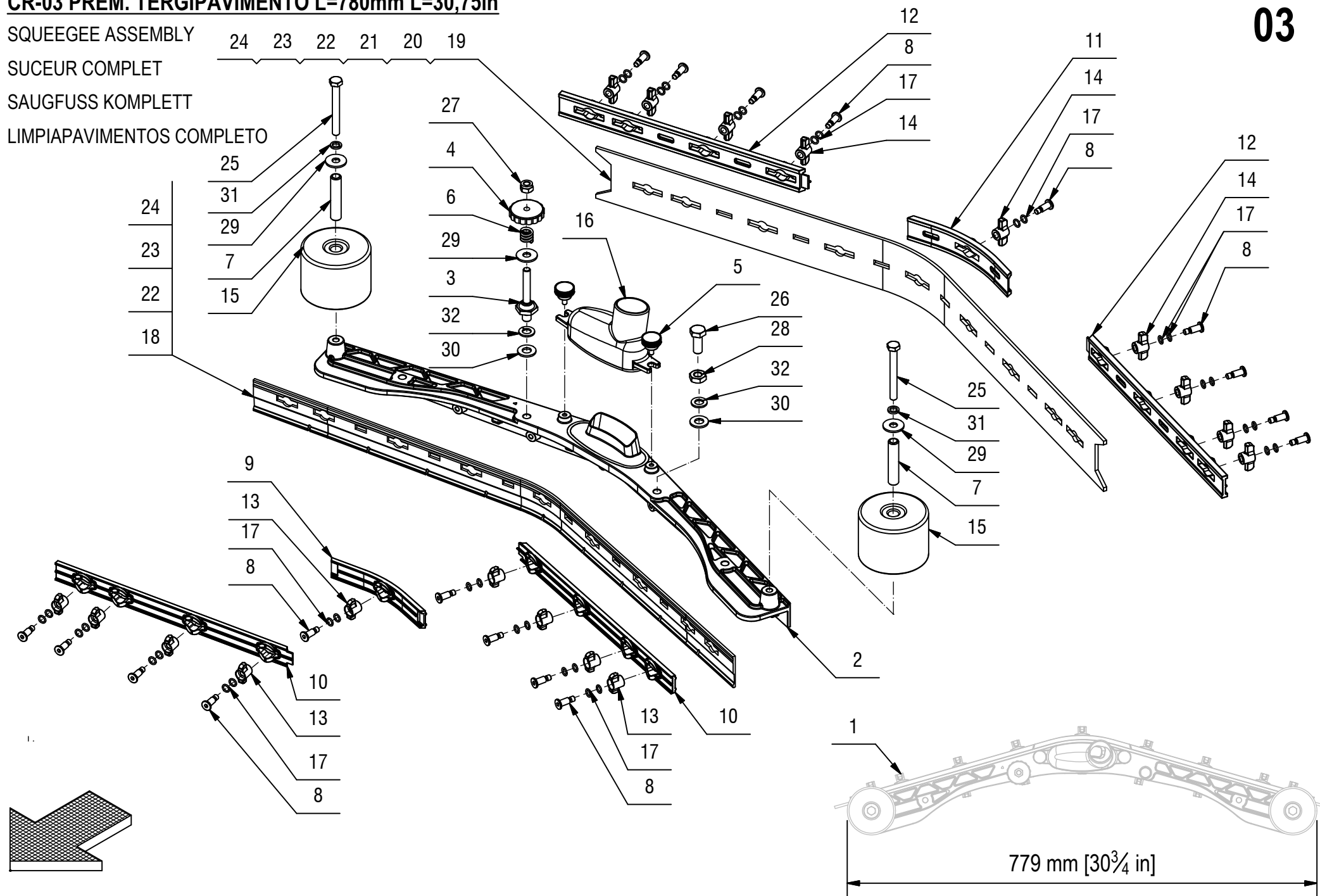

CR-03 PREM. TERGIPAVIMENTO L=780mm L=30,75in

POS.	CODICE	QTÀ	DESCRIZIONE	DENOMINATION	DESCRIPTION	BENENNUNG	DESCRIPCION
1	220806	1	PREM. TERGIPAVIMENTO L=780	SQUEEGEE ASSEMBLY	SUCER COMPLETE	AUGFUSS KOMPLETT	LIMPIAPAVIMENTOS COMPLETO
2	430941	1	CORPO TERGIPAVIMENTO 2010 L=736	SQUEEGEE BODY	CORPS DE SUCEUR	SAUGFUSSKÖRPER	CUERPO LIMPIAPAVIMENTOS
3	219372	1	COLONNETTA SGANCIO M10-CH22 - M8 (28-45)	STUD BOLT	TIGE	GEWINDEBOLZEN	PRISIONERO
4	400112	1	VOLANTINO LOBATO PASSANTE V/40/PS M8	HANDWHEEL	VOLANT	HANDGRIFF	RUEDA DE MANIOBRA
5	435330	2	VOLANTINO ZIGRINATO ZPX/22 M5x10 6331400	KNOB	POMMEAU	RENDELSCHRAUBE	POMO
6	408098	1	MOLLA COMPR. 14,5x15x2,5 COLON. TERGIP.	SPRING	RESSORT	FEDER	RESORTE
7	411765	2	BOCCOLA D=12 d=8,2 S=58,5 OT63	BUSHING	BAGUE	BUCHSE	CASQUILLO
8	430903	18	PERNO MANOPOLINA D=11,8 d=7 M=6 H=22	PIN	AXE	BOLZEN	PERNO
9	430944	1	PREMIGOMMA ANTERIORE CENTRALE TERGI 2010	FRONT BLADE	PLAQUETTE AVANT	VORDERER LEISTE	LISTON DELANTERA
10	430946	2	PREMIGOMMA ANTERIORE L=736 TERGI 2010	FRONT BLADE	PLAQUETTE AVANT	VORDERER LEISTE	LISTON DELANTERA
11	430949	1	PREMIGOMMA POSTERIORE CENTRALE TERGI2010	REAR BLADE	PLAQUETTE ARRIERE	HINTERER LEISTE	LISTON TRASERA
12	430951	2	PREMIGOMMA POSTERIORE L=736 TERGI 2010	REAR BLADE	PLAQUETTE ARRIERE	HINTERER LEISTE	LISTON TRASERA
13	430954	9	GALLETTO CHIUSURA ANTERIORE TERGI 2010	WING NUT	PAPILLON	FLÜGELSCHRAUBE	POMO
14	430955	9	GALLETTO CHIUSURA POSTERIORE TERGI 2010	WING NUT	PAPILLON	FLÜGELSCHRAUBE	POMO
15	430956	2	RUOTA PARACOLPI D=80 d=12 H=60	BUMPER WHEEL	ROUE BUTEE	PUFFER RAD	RUEDA PARACHOQUES
16	430957	1	BOCCHETTA DRITTA D=40 + GUARN. TERGI2010	OPENING	BUSE	ÖFFNUNG	BOQUILLA
17	431633	36	O-RING 7x1,5 NBR 70 SHORE	WASHER	RONDELLE	UNTERLAGSCHEIBE	ARANDELA
18	219375	1	GOMMA ANT. POLIURETANO H=45	FRONT RUBBER	BAVETTE AVANT	VORDERER SAUGGUMMI	GOMA DELANTERA
19	434542	1	GOMMA POST. PARA 33Sh H=70 SP=4	REAR RUBBER	BAVETTE ARRIERE	HINTERER SAUGGUMMI	GOMA TRASERA
20	434543	1	GOMMA POST. POLIUR. H=70 SP=4	REAR RUBBER	BAVETTE ARRIERE	HINTERER SAUGGUMMI	GOMA TRASERA
21	434544	1	GOMMA POST. LATEX H=70 SP=4	REAR RUBBER	BAVETTE ARRIERE	HINTERER SAUGGUMMI	GOMA TRASERA
22	221391	1	KIT GOMME 33 SHORE L=780 SP=4 (POS. 24+26)	KIT RUBBER	KIT BAVETTE	SAUGGUMMIGRUPPE	KIT GOMA
23	221392	1	KIT GOMME POLIURETANO L=780 SP=4 (POS. 24+25)	KIT RUBBER	KIT BAVETTE	SAUGGUMMIGRUPPE	KIT GOMA
24	221393	1	KIT GOMME LATEX L=780 SP=4 (POS. 24+27)	KIT RUBBER	KIT BAVETTE	SAUGGUMMIGRUPPE	KIT GOMA
25	408696	2	VITE M8X70 TE INOX UNI 5739.	SCREW	VIS	SCHRAUBE	TORNILLO
26	408741	1	VITE M10x25 TE UNI 5739 A2	SCREW	VIS	SCHRAUBE	TORNILLO
27	409087	1	DADO M8 AUTOBL. UNI 7474 INOX BASSO	LOCK NUT	ECROU AUTOFREINES	SICHERUNGSMUTTER	TUERCA AUTOBLOCANTE
28	415903	1	DADO M10 UNI5589 A2	NUT	ECROU	MUTTER	TUERCA
29	409185	3	ROSETTA 9x24x2,5 UNI 6593 A2	WASHER	RONDELLE	UNTERLEGSCHLEIBE	ARANDELA
30	409192	2	ROSETTA 10x21x2 UNI 6592 A2	WASHER	RONDELLE	UNTERLAGSCHEIBE	ARANDELA
31	409187	2	ROSETTA GROWER 8x13x2,2 A2	WASHER	RONDELLE	UNTERLAGSCHEIBE	ARANDELA
32	409200	2	ROSETTA GROWER 10x2,5x2,5 A2	LOCK WASHER	RONDELLE FREIN	ZAHNSCHLEIBE	ARANDELLA DENTADA

CR-04 GRUPPO COMANDO TERGIPAVIMENTO

SQUEEGEE CONTROL ASSEMBLY

GROUPE COMMANDE DE SUCEUR

GRUPPE SAUGFUSSBETÄTIGUNG

GRUPO MANDO LIMPIAPAVIMENTOS

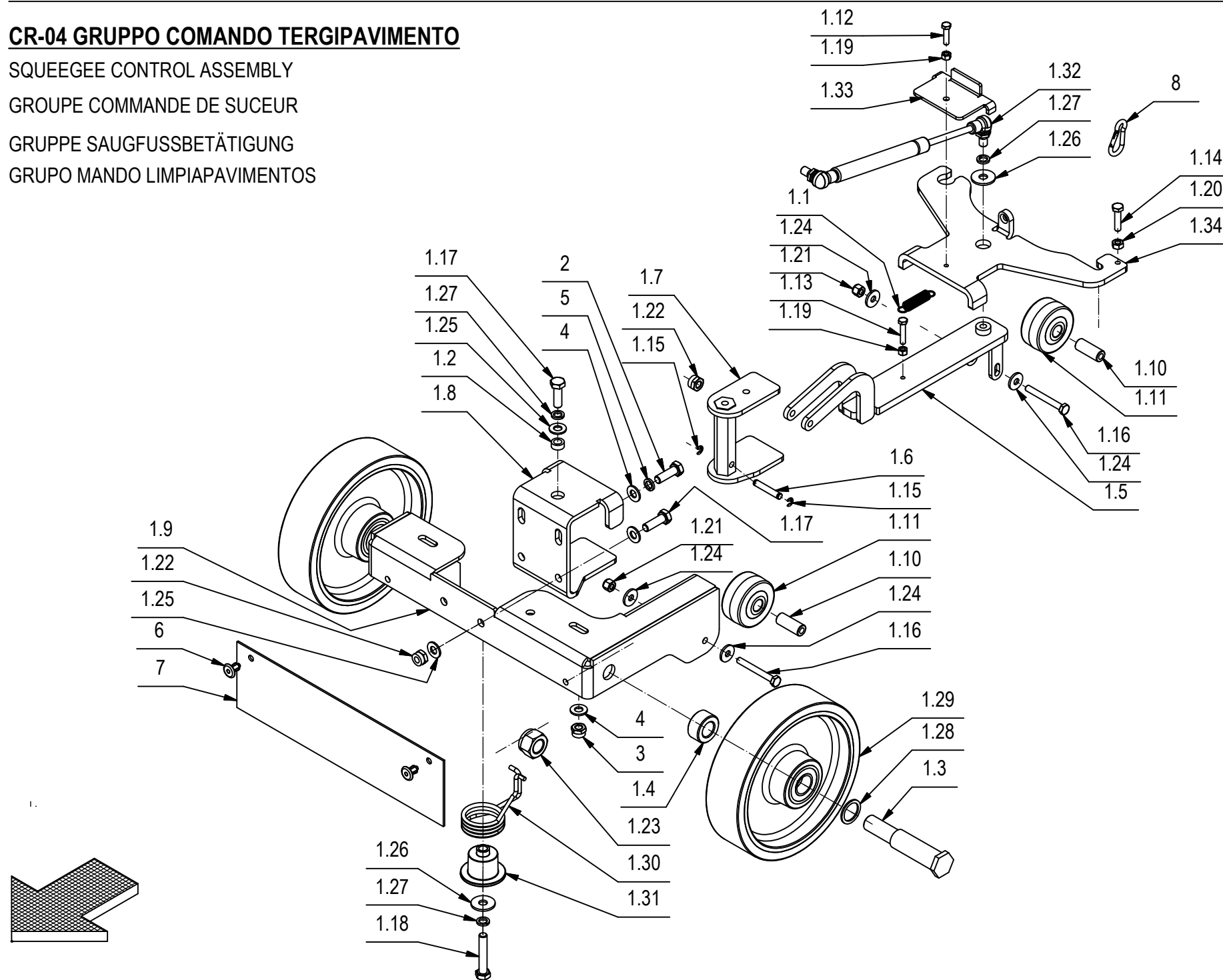
04

CR-04 GRUPPO COMANDO TERGIPAVIMENTO**04**

POS.	CODICE	QTÀ	DESCRIZIONE	DENOMINATION	DESCRIPTION	BENENNUNG	DESCRIPCION
1	224102	1	PREM. COMANDO TERGI MY50 2014				
1.1	202480	1	MOLLA TRAZ. 10X1,1X46 ZINC	SPRING	RESSORT	FEDER	RESORTE
1.2	210168	1	BOCCOLA D=12,9 d=8,2 S=5,5 OT58	BUSHING	BAGUE	BUCHSE	CASQUILLO
1.3	215023	2	PERNO RUOTE D=20 L=105,5 C40	PIN	AXE	BOLZEN	PERNO
1.4	215032	2	DISTANZIALE D=30 d=16 S=15 AVP	SPACER	ENTRETOISE	DISTANZHUELSE	DISTANCIADOR
1.5	220805	1	BRACCIO ANTERIORE TERGI MY 50	FRONT ARM	BRAS AVANT	VORDERE ARM	BRAZO DELANTERO
1.6	220808	1	PERNO D.6x35 CON SEDI ANELLO	PIN	AXE	BOLZEN	PERNO
1.7	220810	1	PERNO ROTAZIONE TERGI MY 50	PIN	AXE	BOLZEN	PERNO
1.8	220812	1	STAFFA SUPPORTO ATTACCO TERGI MY 50	SUPPORT	SUPPORT	HALTERUNG	SOPORTE
1.9	220814	1	SUPP. RUOTE-ATTACCO TERGI MY 50	SUPPORT	SUPPORT	HALTERUNG	SOPORTE
1.10	400152	2	PERNO D=12 d=6,25 S=30,5 C40	PIN	AXE	BOLZEN	PERNO
1.11	405682	2	RUOTA D=52 d=12,5 S=28 DESMOPAN	IDLE WHEEL	ROUE FOLLE	LOSRAD	RUEDA LIBRE
1.12	407647	1	VITE M5x20 TE UNI 5739 ZINC	SCREW	VIS	SCHRAUBE	TORNILLO
1.13	407651	1	VITE M5X25 TE UNI 5739 DIN 933 (8.8)ZINC	SCREW	VIS	SCHRAUBE	TORNILLO
1.14	407669	1	VITE M6x25 TE UNI 5739 ZINC	SCREW	VIS	SCHRAUBE	TORNILLO
1.15	408367	2	SEEGER RS 4 DIN 6799	SEEGER RING	SERRE CLIPS	SEEGER RINGS	ANILLO SEEGER
1.16	408657	2	VITE M6X50 TE UNI 5739 A2	SCREW	VIS	SCHRAUBE	TORNILLO
1.17	408674	3	VITE M8x25 TE UNI 5739 ZINC	SCREW	VIS	SCHRAUBE	TORNILLO
1.18	408681	1	VITE M8x45 TE UNI 5739 ZINC	SCREW	VIS	SCHRAUBE	TORNILLO
1.19	409036	2	DADO M5x5 UNI 5587 ZINC	NUT	ECROU	MUTTER	TUERCA
1.20	409040	1	DADO M6x5 UNI 5588 ZINC	NUT	ECROU	MUTTER	TUERCA
1.21	409083	2	DADO M6x8 AUTOBL. UNI 7473 DIN 982 A2	NUT	ECROU	MUTTER	TUERCA
1.22	409085	3	DADO M8x8.5 AUTOBL. UNI 7474 ZINC	LOCK NUT	ECROU AUTOFREINES	SICHERUNGSMUTTER	TUERCA AUTOBLOCANTE
1.23	409097	2	DADO M16x15x1,5 AUTOBL. UNI 7474	LOCK NUT	ECROU AUTOBLOQUANT	STOPMUTTER	TUERCA AUTOBLOCANTE
1.24	409161	4	ROSETTA 6,6x18x2 UNI 6593 A2	WASHER	RONDELLE	SCHEIBE	ARANDELA
1.25	409175	5	ROSETTA 8x17x1,6 UNI 6592 ZINC.	WASHER	RONDELLE	UNTERLAGSCHEIBE	ARANDELA
1.26	409179	2	ROSETTA 9x24x2,5 UNI 6593 ZINC	WASHER	RONDELLE	UNTERLAGSCHEIBE	ARANDELA
1.27	409181	3	ROSETTA GROWER 8x13x2,2 ZINC	LOCK WASHER	RONDELLE FREIN	ZAHNSCHEIBE	ARANDELLA DENTADA
1.28	409228	2	RONDELLA 20x26x1,5 ALLUMINIO	WASHER	RONDELLE	UNTERLAGSCHEIBE	ARANDELA
1.29	420679	2	RUOTA D=172.5 L=45.5 CON CUSCINETTI	WHEEL	ROUE	RAD	RUEDA
1.30	420965	1	MOLLA COMANDO ROTAZIONE TERGI	SPRING	RESSORT	FEDER	RESORTE
1.31	433669	1	BOCCOLA MOLLA EXTRA CORSA TERGI MY 50	BUSHING	BAGUE	BUCHSE	CASQUILLO
1.32	433681	1	MOLLA A GAS CON SNODI ANG. 200N L=274	GAS SHOCK ABSORBER	RESSORT	GASFEDER	AMORTIGUADOR A GAS
1.33	438246	1	STAFFA FINE CORSA MOLLA GAS MY50	SUPPORT	SUPPORT	HALTERUNG	SOPORTE
1.34	439804	1	BRACCIO POSTERIORE TERGI MY50 2014	REAR ARM	BRAS ARRIERE	HINTERER ARM	BRAZO TRASERO
2	408674	2	VITE M8x25 TE UNI 5739 ZINC	SCREW	VIS	SCHRAUBE	TORNILLO
3	409085	3	DADO M8x8.5 AUTOBL. UNI 7474 ZINC	LOCK NUT	ECROU AUTOFREINES	SICHERUNGSMUTTER	TUERCA AUTOBLOCANTE
4	409175	5	ROSETTA 8x17x1,6 UNI 6592 ZINC.	WASHER	RONDELLE	UNTERLAGSCHEIBE	ARANDELA

CR-04 GRUPPO COMANDO TERGIPAVIMENTO

SQUEEGEE CONTROL ASSEMBLY

GROUPE COMMANDE DE SUCEUR

GRUPPE SAUGFUSSBETÄTIGUNG

GRUPO MANDO LIMPIAPAVIMENTOS

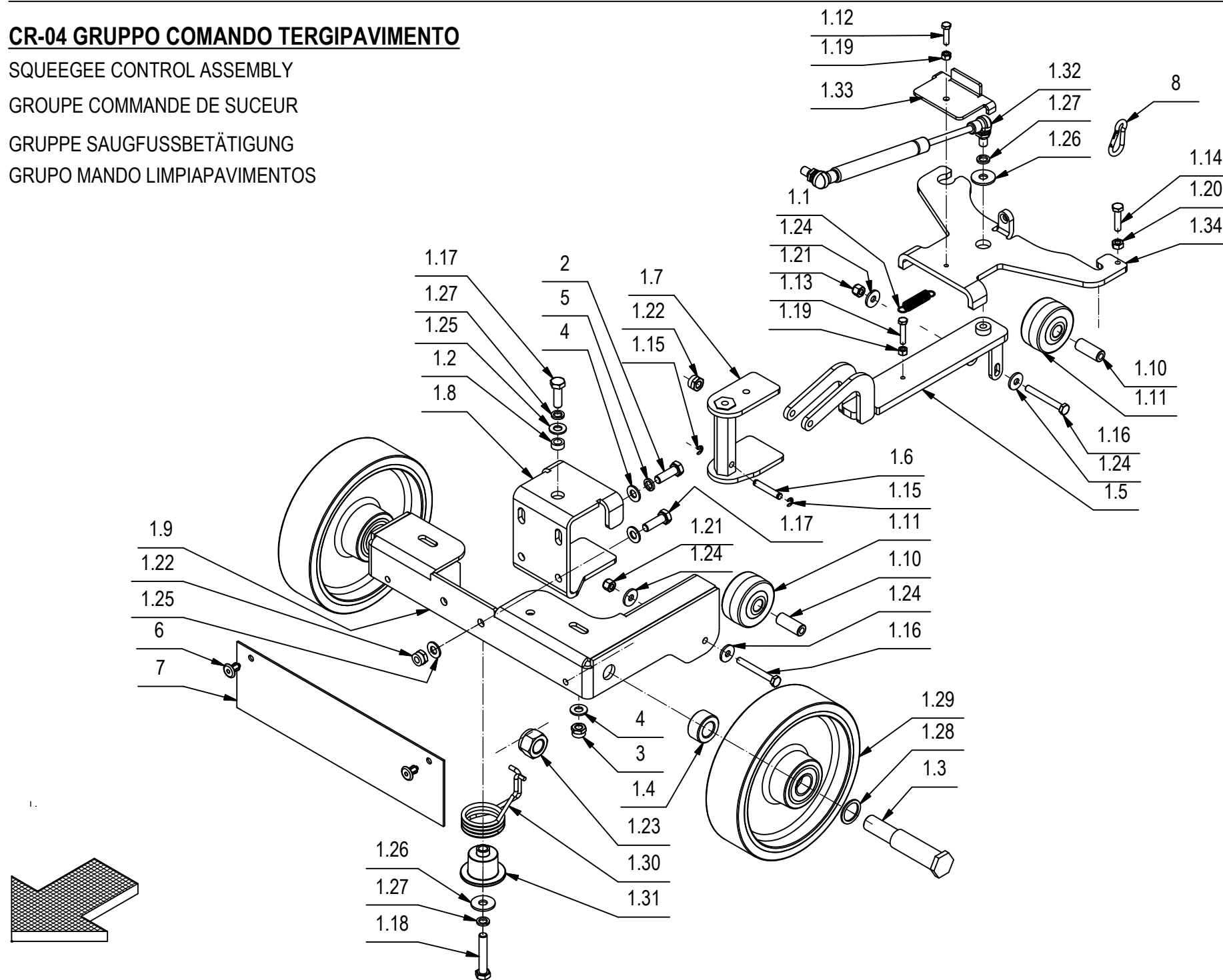
04

CR-04 GRUPPO COMANDO TERGIPAVIMENTO**04**

POS.	CODICE	QTÀ	DESCRIZIONE	DENOMINATION	DESCRIPTION	BENENNUNG	DESCRIPCION
5	409181	2	ROSETTA GROWER 8x13x2,2 ZINC	LOCK WASHER	RONDELLE FREIN	ZAHNSCHEIBE	ARANDELLA DENTADA
6	415952	2	RIVETTO 6.4X10 NYLON	RIVET	RIVET	NIET	CLAVO
7	433680	1	GOMMA LUBRITENE 290x80x2	RUBBER	BAVETTE	GUMMI	GOMA
8	433682	1	MOSCHETTONE 4x40 ACCIAIO ZINCATO	CARABINIER	MOUSQUETON	KARABINERHAKEN	MOSQUETON

CR-06 GRUPPO SERBATOIO (VER. RAL7016)

TANK & WATER UNIT ASSEMBLY

GROUPE DE RESERVOIRS & HIDRIQUE

TANK & WASSERGRUPE

GRUPO TANQUES & AGUA

06

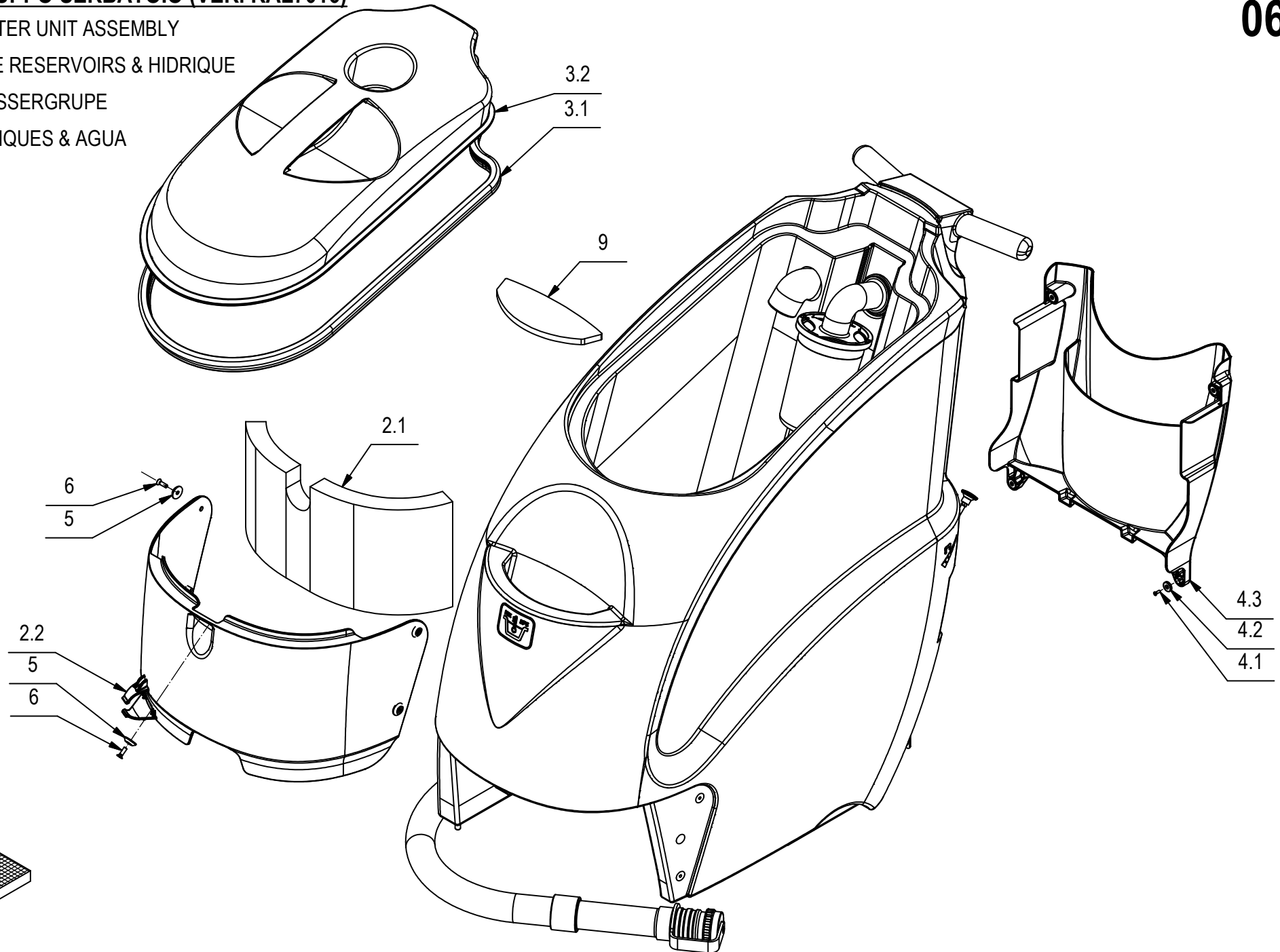

CR-06 GRUPPO SERBATOIO (VER. RAL7016)**06**

POS.	CODICE	QTÀ	DESCRIZIONE	DENOMINATION	DESCRIPTION	BENENNUNG	DESCRIPCION
1	220792	1	PREM. SERBATOIO MY 50	TANK ASSEMBLY	GROUPE DE RESERVOIR	GRUPPE TANK	GRUPO TANQUE
1.1	416172	1	FASCETTA A VITE 15-24 ABA	CLAMP	COLLIER	BRIDE	ABRAZADERA
1.2	220789	1	STAFFA GUIDA ASTA RUBINETTO MY 50	SUPPORT	SUPPORT	HALTERUNG	SOPORTE
1.3	220791	1	ASTA RUBINETTO MY 50	ROD	TIGE	STANGE	VARILLA
1.4	432150	1	TUBO DIAM. 38X1310 SPIRALATO CON GOMITO	SUCTION HOSE	FLEXIBLE ASPIRATION	SAUGSCHLAUCH	TUBO DE ASPIRACION
1.5	400854	1	LEVA RUBINETTO CORTA	COCK LEVER	LEVIER DE ROBINET	WASSERHAHNHEBEL	PALANCA DE GRIFO
1.6	405960	2	GUARNIZIONE GOMMA PER RACCORDO 410397	GASKET	JOINT	DICHTUNG	JUNTA
1.7	418311	8	VITE M5x10 TCTC UNI 7687 (4.8) ZINC.	SCREW	VIS	SCHRAUBE	TORNILLO
1.8	408854	1	VITE M5x16 TCTC UNI EN ISO 704	SCREW	VIS	SCHRAUBE	TORNILLO
1.9	409151	1	ROSETTA 5,5x15x1,5 UNI 6593 ZINC	WASHER	RONDELLE	UNTERLAGSCHEIBE	ARANDELA
1.10	220786	1	TUBO TRASPARENTE METALFLEX-I D=18 x 780	PIPE	TUBE	ROHR	TUBO
1.11	409810	1	PASSAFILO DIAM. 8x12x1,5	FAIRLEAD	PASSE-CABLE	KABELDURCHGANG	GUIACABLE
1.12	409819	5	BASSETTA TC 142 PER FASCETTE	SUPPORT PLATE	PLAQUE SUPPORT	STÜTZPLATTE	PLACA SOPORTE
1.13	410277	5	FASCETTA PLASTICA 4.5X200	CLAMP	COLLIER	BRIDE	ABRAZADERA
1.14	222018	1	STAFFA FERMA BATTERIE POSTERIORE MY50	SUPPORT	ATTAQUE	HALTERUNG	SOPORTE FIJADOR
1.15	410290	1	FASCETTA A VITE 32-44x12,2	CLAMP	COLLIER	BRIDE	ABRAZADERA
1.16	410332	1	CORPO RUBINETTO 3/8 FORO FIL. M5	COCK	ROBINET	WASSERHAHN	GRIFO
1.17	410376	1	PORTAGOMMA DIRITTO 3/8" M D12	CONNECTOR	RACCORD	SCHLAUCHANSCHLUSS	EMPALME TUBO DE GOMA
1.18	410386	1	PORTAGOMMA DIRITTO 1/2" M. D=20	CONNECTOR	RACCORD	SCHLAUCHANSCHLUSS	EMPALME TUBO DE GOMA
1.19	410397	1	RACCORDO PORTAGOMMA DIRITTO D38	FITTING	RACCORD	VERSCHRAUBUNG	RACOR
1.20	438717	1	SERBATOIO MY 50 RAL 7016	TANK	RESERVOIR	TANKE	TANQUE
1.21	412123	1	CLIP ABS FISSAGGIO TUBO D=38	SPRING	RESSORT	FEDER	RESORTE
1.22	412363	1	ASSIEME FILTRO A CARTUCCIA D=60 H=130	FILTER ASSEMBLY	FILTRE COMPLET	FILTER KOMPLETT	FILTRO COMPLETO
1.23	415637	2	ANELLO EL. RAD. 5 DIN 6799	STOP RING	BAGUE D'ARRET	STOPRING	ANILLO DE PARADA
1.24	409175	3	ROSETTA 8x17x1,6 UNI 6592 ZINC.	WASHER	RONDELLE	UNTERLAGSCHEIBE	ARANDELA
1.25	426339	1	FONOAS. BUGNATO ADES. D.130 H30 - MAXI	DEADENING	ISOLANT PHONIQUE	SCHALLDICHTUNG	FONOABSORBENTE
1.26	416257	1	GHIERA 1" 1/4	RING NUT	EMBOUT	NUTMUTTER	TUERCA ANULAR
1.27	410280	1	FASCETTA PLASTICA 7,8x240	CLAMP	COLLIER	BRIDE	ABRAZADERA
1.28	410431	1	NIPPOLO MM 3/8"-3/8" OTTONE FILET. CONICO	EXHAUST PIPE	FLEXIBLE DE VIDANGE	ABWASSERSCHLAUCH	TUBO DE DESCARGA
1.29	409034	1	DADO M4x4 UNI 5587 ZINC	NUT	ECROU	MUTTER	TUERCA
1.30	426342	1	TAPPO RIEMPIMENTO RAPIDO SOLUZIONE MX	CAP	CAPUCHON	KAPPE	TAPON
1.31	424552	1	TUBO D.38X985 SPIRALATO TAPPO INTEGRATO	EXHAUST PIPE ASSEMBLY	FLEXIBLE DE VIDANGE COMPL.	ABWASSERSCHLAUCH KOMPL.	TUBO DE DESCARGA COMPLETO
1.32	415750	3	VITE M5x12 TSPTC UNI 7688 (4.8) ZINC.	SCREW	VIS	SCHRAUBE	TORNILLO
1.33	433645	1	POMELLO GAMM M4 x Ø26 NERO	KNOB	POMMEAU	RENDELSCHRAUBE	POMO
1.34	433646	1	TUBO SPIRALATO D.38 x 1394 - 2 MANIC.90°	SUCTION HOSE	FLEXIBLE ASPIRATION	SAUGSCHLAUCH	TUBO DE ASPIRACION
1.35	433650	1	RACCORDO RIEMPIMENTO PER TUBO Ø18 - MY50	FITTING	RACCORD	VERSCHRAUBUNG	RACOR
1.36	433651	1	RACCORDO ATTACCO GALLEGGIANTE TUBO D.38	FITTING	RACCORD	VERSCHRAUBUNG	RACOR
1.37	433652	1	PROTEZIONE GALLEGGIANTE D.110 x 182 MY50	FLOAT PROTECTION	FLOTTEUR PROTECTION	SCHWIMMERE ABDECKUNG	PROTECCION FLOTADOR

CR-06 GRUPPO SERBATOIO (VER. RAL7016)

TANK & WATER UNIT ASSEMBLY

GROUPE DE RESERVOIRS & HIDRIQUE

TANK & WASSERGRUPE

GRUPO TANQUES & AGUA

06

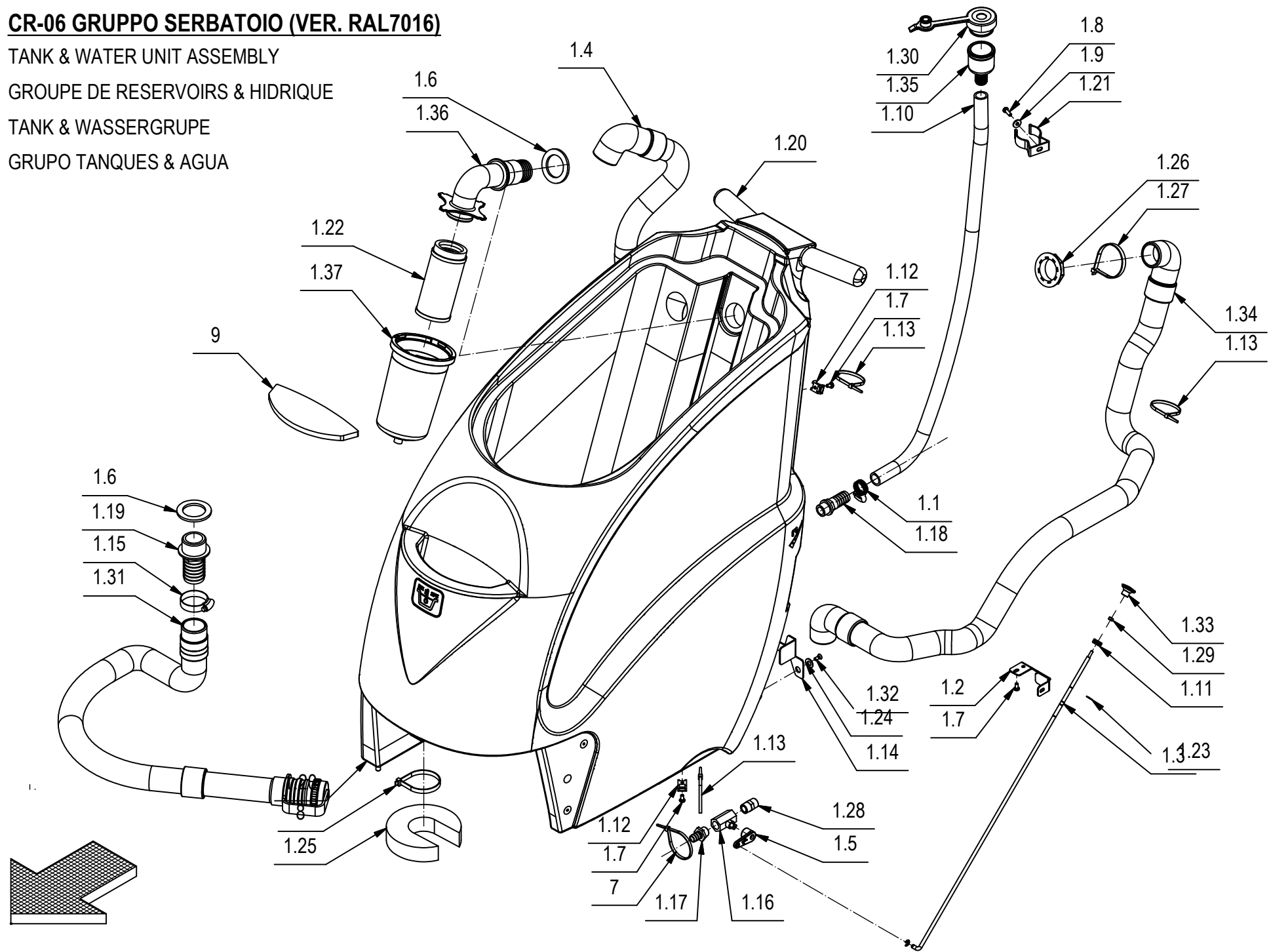

CR-06 GRUPPO SERBATOIO (VER. RAL7016)**06**

POS.	CODICE	QTÀ	DESCRIZIONE	DENOMINATION	DESCRIPTION	BENENNUNG	DESCRIPCION
2	220797	1	PREM. CARTER ANTERIORE MY 50	COVER	CARTER	ABDECKUNG	CARTER
2.1	433655	1	FONOASSORBENTE BUGNATO ADES. 394x190 H30	DEADENING	ISOLANT PHONIQUE	SCHALLDICHTUNG	FONOABSORBENTE
2.2	433656	1	CARTER ANTERIORE MY 50	COVER	CARTER	ABDECKUNG	CARTER
3	220799	1	PREM. COPERCHIO VANO RECUPERO MY 50	COVER	COUVERCLE	DECKEL	TAPA
3.1	220798	1	GUARNIZIONE COPERERCHIO MY 50	PROFILE	PROFIL	PROFIL	PERFIL
3.2	433658	1	COPERCHIO VANO RECUPERO MY 50	COVER	COUVERCLE	DECKEL	TAPA
4	220800	1	PREM. CARTER POSTERIORE BATTERIE MY 50	COVER	CARTER	ABDECKUNG	CARTER
4.1	408922	4	VITE M3x10 TPS UNI 6109 A2	SCREW	VIS	SCHRAUBE	TORNILLO
4.2	430184	4	MAGNETE D15 x d3 x 3 F=3 Kg	MAGNET	AIMANT	MAGNET	IMAN
4.3	433660	1	CARTER POSTERIORE COPRI BATTERIE MY 50	COVER	CARTER	ABDECKUNG	CARTER
5	400250	5	ROSETTA SOTTOVITE D=5X20	SPECIAL WASHER	RONDELLE SPECIALE	UNTERLAGSCHEIBE SPEZIAL	ARANDELA ESPECIAL
6	408516	5	VITE M5x16 TSCTC UNI 7689 ZINC	SCREW	VIS	SCHRAUBE	TORNILLO
7	410277	1	FASCETTA PLASTICA 4.5X200	CLAMP	COLLIER	BRIDE	ABRAZADERA
8	410280	1	FASCETTA PLASTICA 7,8x240	CLAMP	COLLIER	BRIDE	ABRAZADERA
9	433644	1	FILTRO IN STOFFA CARICO SERB. SOL. MY 50	FILTER	FILTRE	FILTER	FILTRO

CR-10 GRUPPO IMPIANTO ELETTRICO

ELECTRIC COMPONENTS

COMPOSANTS ELETRIQUES

GRUPPE ELEKTROTEILE

COMPONENTES ELECTRICOS

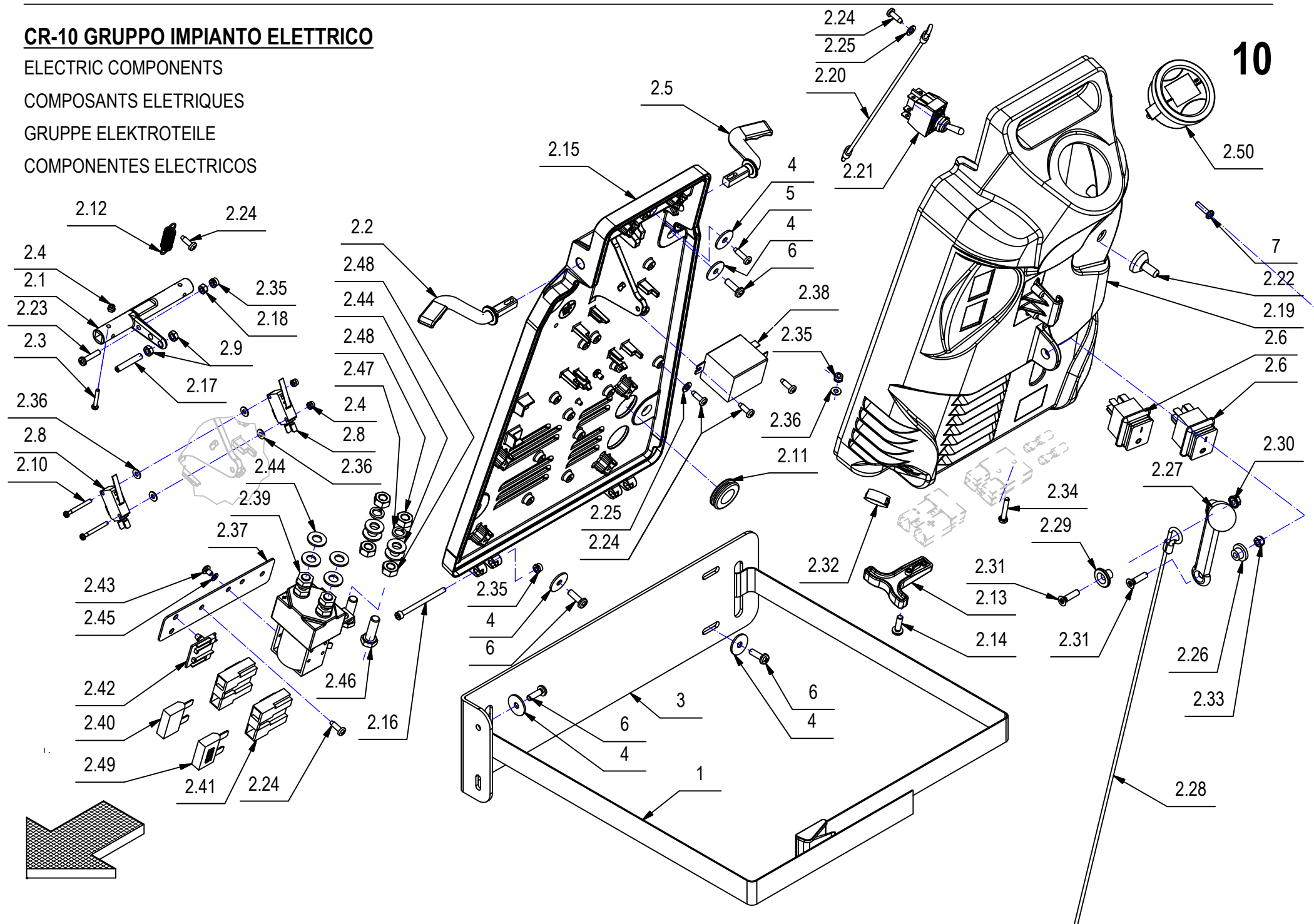

CR-10 GRUPPO IMPIANTO ELETTRICO**10**

POS.	CODICE	QTÀ	DESCRIZIONE	DENOMINATION	DESCRIPTION	BENENNUNG	DESCRIPCION
1	424822	1	CINGHIA L=1450X25 FERMA BATTERIA	SUPPORT	ATTAQUE	HALTERUNG	SOPORTE FIJADOR
2	224262	1	PREM. IMPIANTO ELETTRICO				
2.1	426351	1	CAMMA COMANDO MARCIA	CAM	CAME	NOCKEN	LEVA
2.2	426344	1	LEVA COMANDO MARCIA SX	LEVER	LEVIER	HEBEL	PALANCA
2.3	408834	2	VITE M3X20 TCTC UNI 7687 ZINC	SCREW	VIS	SCHRAUBE	TORNILLO
2.4	409077	4	DADO M3x4,5 AUTOBL. UNI 7474 ZINC	LOCK NUT	ECROU AUTOFREINES	SICHERUNGSMUTTER	TUERCA AUTOBLOCANTE
2.5	426345	1	LEVA COMANDO MARCIA DX	LEVER	LEVIER	HEBEL	PALANCA
2.6	417622	2	INTERRUPTORE BIPOLARE NERO A SOFFIETTO	BLACK BIPOLAR SWITCH	INTERRUPTEUR	SCHALTER	INTERRUPTOR
2.8	409499	2	MICRO 16A 3x22 LEVA CORTA	MICROSWITCH	MICROINTERRUPTEUR	MIKROSCHALTER	MICROINTERRUPTOR
2.9	409038	2	DADO M5x3,5 UNI 5589 ZINC	LOCK NUT	ECROU AUTOFREINES	SICHERUNGSMUTTER	TUERCA AUTOBLOCANTE
2.10	408836	2	VITE M3x30 TCTC UNI 7687 ZINC	SCREW	VIS	SCHRAUBE	TORNILLO
2.11	409809	1	PASSACAPO PER FORO D.25 Di=15	FAIRLEAD	PASSE-CABLE	KABELDURCHGANG	GUIACABLE
2.12	408121	1	MOLLA TRAZ. 10x1.1x38 A2	SPRING	RESSORT	FEDER	RESORTE
2.13	409683	1	MANIGLIA PER CONNETTORE 50A	HANDLE	MANCHE	HANDGRIFF	MANILLA
2.14	408893	2	VITE D.5x17 AUTOF. POLI LOCK SPUNTATA	SCREW	VIS	SCHRAUBE	TORNILLO
2.15	433725	1	CRUSCOTTO INTERNO	INNER INSTRUMENT BOARD	TABLEAU DE BORD INTERIEUR	ARMATURENBRETT INNEN	TABLERO DE INSTRUMENTOS INT.
2.16	433724	2	VITE M4x55 TCEI UNI 5931 8.8 ZINC	SCREW	VIS	SCHRAUBE	TORNILLO
2.17	415811	1	GRANO M5x30 UNI 5925 PIANO	DOWEL	VIS CYLINDRIQUE	MADENSCHRAUBE	TORNILLO
2.18	409034	1	DADO M4x4 UNI 5587 ZINC	NUT	ECROU	MUTTER	TUERCA
2.19	433727	1	CRUSCOTTO ESTERNO	INSTRUMENT BOARD	TABLEAU DE BORD	ARMATURENBRETT	TABLERO DE INSTRUMENTOS
2.20	220838	1	FUNE TRECCIA POLYESTER F.16 D=3 x 400	CABLE	CABLE	KABEL	CUERDA
2.21	434431	1	INTERRUPTORE BIP. ON-MOM 645H/2 10A 250V	SWITCH	INTERRUPTEUR	SCHALTER	INTERRUPTOR
2.22	434432	1	CAPPUCCIO NEOPRENE NERO APEM IU1001	PROTECTION CAP	CALOTTE DE PROTECTION	SICHERHEITSKAPPE	CAPUCHO DE PROTECCION
2.23	415782	1	VITE M4X20 TCTC UNI 7687 ZINC	SCREW	VIS	SCHRAUBE	TORNILLO
2.24	408880	7	VITE D.4.2x13 AUTOF.UNI 10227 X PLASTICA	SCREW	VIS	SCHRAUBE	TORNILLO
2.25	409150	2	ROSETTA 5X11X1 UNI 6592 ZINC	WASHER	RONDELLE	UNTERLAGSCHEIBE	ARANDELA
2.26	414707	1	BOCCOLA D=16-10 d=5 S=8 OT58	BUSHING	BAGUE	BUCHSE	CASQUILLO
2.27	423323	1	LEVA COMANDO TERGI.	LEVER	LEVIER	HEBEL	PALANCA
2.28	221594	1	FUNE TRECCIA POLYESTER F.16 D=3 x 538	CABLE	CABLE	KABEL	CUERDA
2.29	221578	1	BOCCOLA D=18-8 d=5,2 S=10,5	BUSHING	BAGUE	BUCHSE	CASQUILLO
2.30	409124	1	DADO M5 SERPRESS	NUT	ECROU	MUTTER	TUERCA
2.31	408892	2	VITE M5X20 TSCTC UNI 7689 ZINC	SCREW	VIS	SCHRAUBE	TORNILLO
2.32	409829	1	TAPPO A SCATTO D.20,6 HEYCO	COVER	COUVERCLE	DECKEL	TAPA
2.33	416781	1	DADO M5X5 AUTOBL. UNI 7473 ZINC	LOCK NUT	ECROU AUTOFREINES	SICHERUNGSMUTTER	TUERCA AUTOBLOCANTE
2.34	408635	2	VITE M4X25 TE UNI 5739 ZINC	SCREW	VIS	SCHRAUBE	TORNILLO
2.35	415898	5	DADO M4 AUTOBL UNI7474	LOCK NUT	ECROU AUTOBLOQUANT	STOPMUTTER	TUERCA AUTOBLOCANTE
2.36	409142	6	ROSETTA 4x9x0,8 UNI 6592 ZINC	WASHER	RONDELLE	UNTERLAGSCHEIBE	ARANDELA

CR-10 GRUPPO IMPIANTO ELETTRICO

ELECTRIC COMPONENTS

COMPOSANTS ELETRIQUES

GRUPPE ELEKTROTEILE

COMPONENTES ELECTRICOS

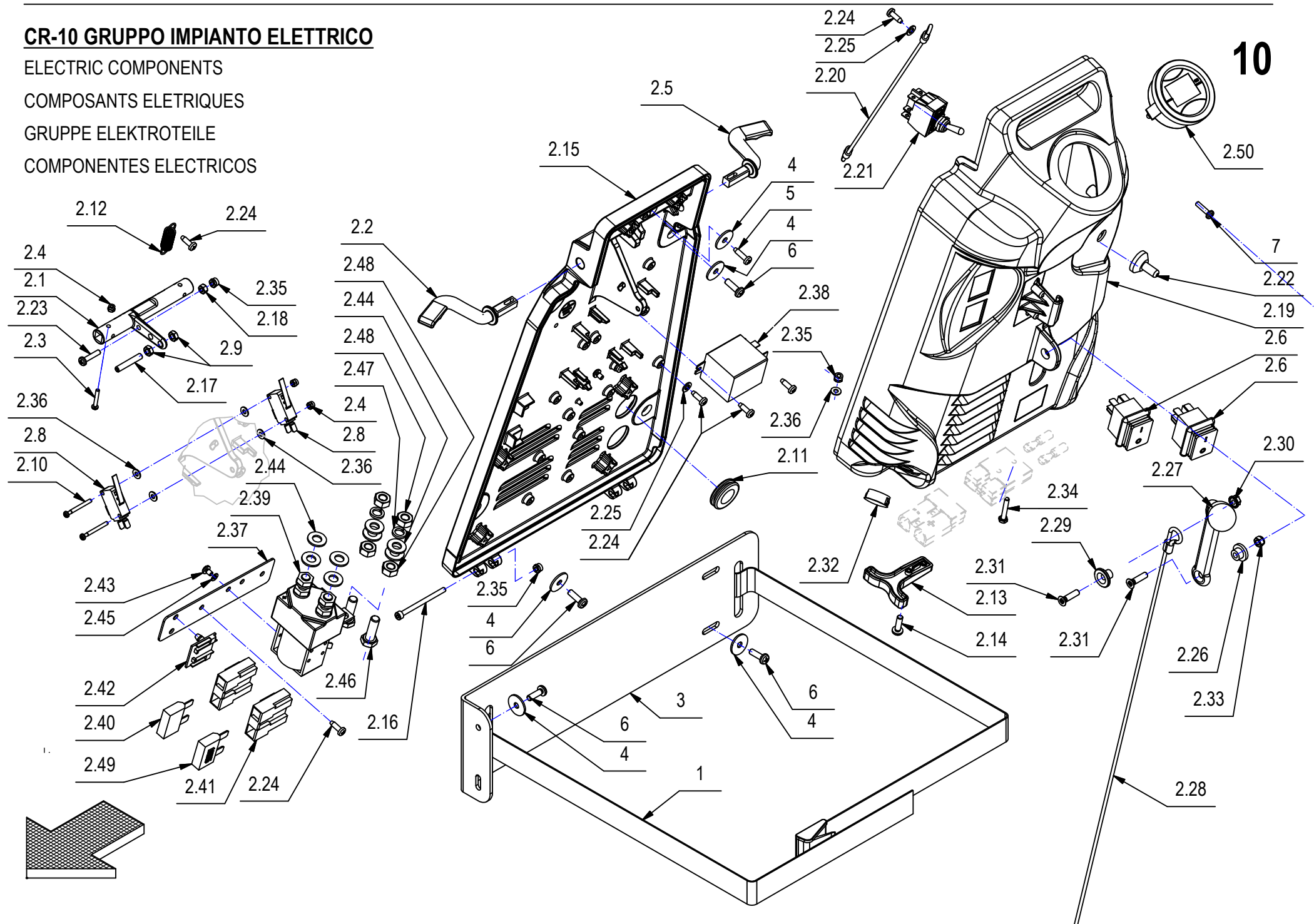

CR-10 GRUPPO IMPIANTO ELETTRICO**10**

POS.	CODICE	QTÀ	DESCRIZIONE	DENOMINATION	DESCRIPTION	BENENNUNG	DESCRIPCION
2.37	220541	1	PIASTRA TELERUTTORE				
2.38	407580	1	RELE FINDER 65.31 - 24V 30A 1 VIA FASTON	RELAY	RELAIS	RELAIS	RELE FINDER
2.39	407578	1	TELERUTTORE DOPPIO 24V 100A	DOUBLE REMOTE CONTR SW	TELERUPTEUR DOUBLE	DOPPELSCHÜTZ	TELERRUPTOR DOBLE
2.40	409607	1	MAXIFUSIBILE 30A	MAXIFUSE	MAXIFUSIBLE	MAXISICHERUNG	MAXIFUSIBLE
2.41	409586	2	PORTAMAXIFUSIBILE 30A	FUSEHOLDER	PORTE-FUSIBLE	SICHERUNGSHALTER	PORTAFUSIBLE
2.42	409872	1	PIASTRINA FISSAGGIO PORTA MAXIFUSIBILE	STOP	ARRET	STOPBELEG	PLAQUETA DE SUJECION
2.43	408768	2	VITE M4x6 TCTC UNI 7687 ZINC	SCREW	VIS	SCHRAUBE	TORNILLO
2.44	409176	8	ROSETTA 8x17x1.6 UNI 6592 OTTONE	WASHER	RONDELLE	UNTERLAGSCHEIBE	ARANDELA
2.45	415941	2	ROSETTA 4 UNI1751 ZINC GROWER	LOCK WASHER	RONDELLE FREIN	ZAHNSCHEIBE	ARANDELLA DENTADA
2.46	408674	2	VITE M8x25 TE UNI 5739 ZINC	SCREW	VIS	SCHRAUBE	TORNILLO
2.47	415946	2	ROSETTA M8 GROWER UNI 1751	LOCK WASHER	RONDELLE FREIN	ZAHNSCHEIBE	ARANDELLA DENTADA
2.48	409046	4	DADO M8x6,5 UNI 5588 ZINC	NUT	ECROU	MUTTER	TUERCA
2.49	409612	1	MAXIFUSIBILE 50A	FUSE	FUSIBLE	SICHERUNG	FUSIBLE
2.50	440063	1	CONTAORE CON INDICATORE BATTERIA NE306	HOUR METER	COMPTEUR HORAIRE	BETRIEBSSTUNDENZÄHLER	CUENTAHORAS
3	220801	1	STAFFA FERMO BATTERIE	ELECTRIC COMPONENTS	COMPOSANTS ELECTRIQUES	GRUPPE ELEKTROTEILE	COMPONENTES ELÉCTRICOS
4	417989	9	RONDELLA 5.5x20x1.5 ZNT DIN 9021	WASHER	RONDELLE	UNTERLAGSCHEIBE	ARANDELA
5	408881	1	VITE D.4,2x16 AUTOF. UNI 6954	SCREW	VIS	SCHRAUBE	TORNILLO
6	408854	8	VITE M5X16 TCTC UNI EN ISO 704	SCREW	VIS	SCHRAUBE	TORNILLO
7	408846	2	VITE M4X16 TCTC UNI 7687 ZINC	SCREW	VIS	SCHRAUBE	TORNILLO
8	436079	1	KIT CAVI	CABLE	CABLE	KABEL	CABLE

CR-11 KIT CARICA BATTERIE

GROUP OPTIONAL CHARGER

GRUPE OPTIONNEL CHARGEUR DE BATTERIES

GRUPPE WAHLFREIER CARICABATTERIE

GRUPO OPCIONAL CARGADOR DE BATERIAS

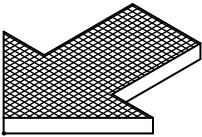
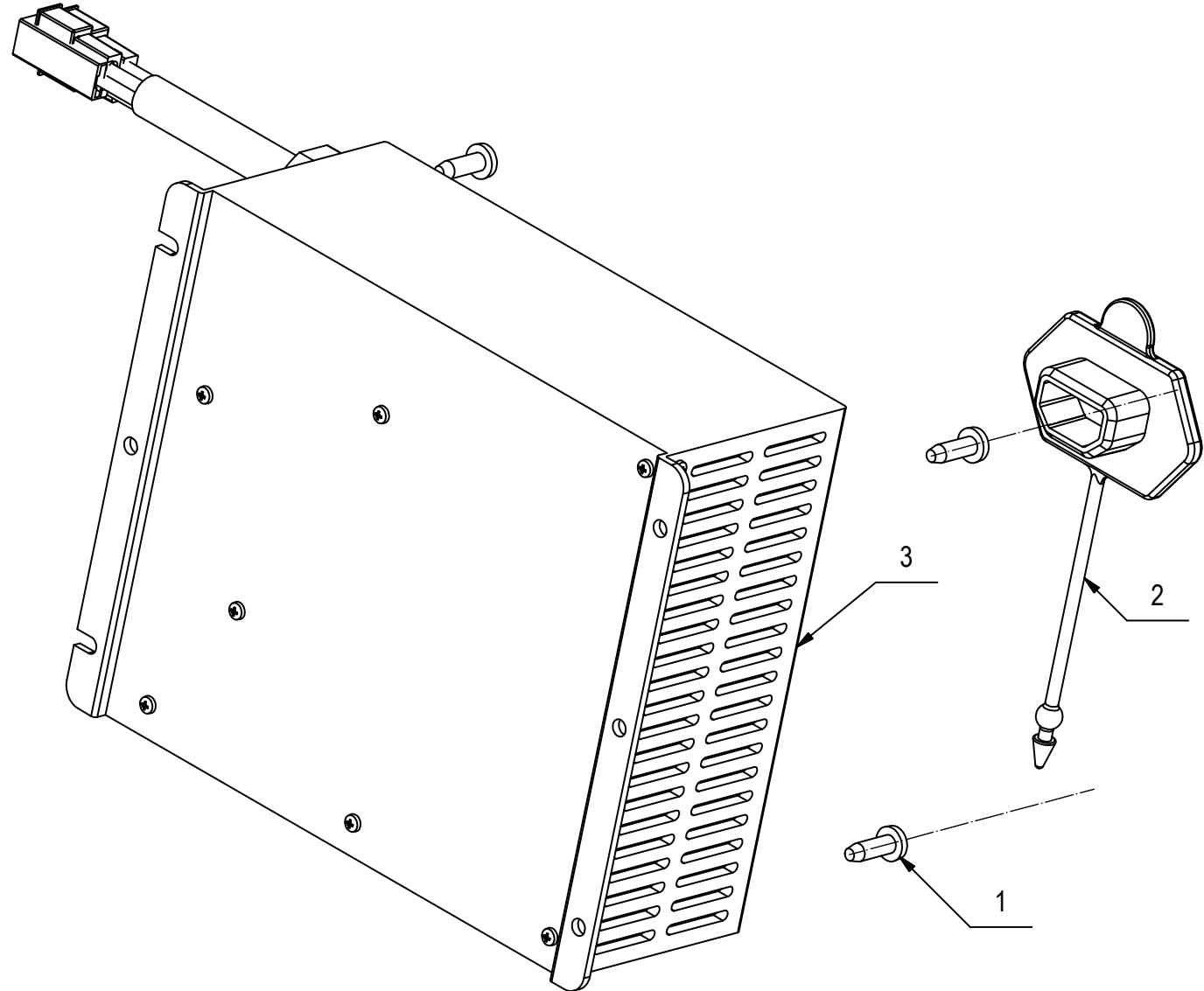

CR-11 KIT CARICA BATTERIE**11**

POS.	CODICE	QTÀ	DESCRIZIONE	DENOMINATION	DESCRIPTION	BENENNUNG	DESCRIPCION
1	408880	4	VITE D.4.2x13 AUTOF.UNI 10227 X PLASTICA	SCREW	VIS	SCHRAUBE	TORNILLO
2	422693	1	PROTEZIONE PRESA DI CORRENTE	PROTECTION	PROTECTION	ABDECKUNG	PROTECCION
3	437657	1	CARICABATTERIE NE 286 24V 11A	BATTERY CHARGER 24V 11A	CHARGEUR DE BATTERIES	LADEGERAET	CARGA DE BATERIAS

CR-12 GRUPPO ETICHETTE

GROUP DECAL
GROUPES DE ETIQUETTE
GRUPPE SCHILD
GRUPOS ETIQUETA



437448

437448 label with FSS logo, diagram of a spray nozzle with parts A, B, C, and a table showing flow rates and autonomy for each setting.



436495



437528

434290

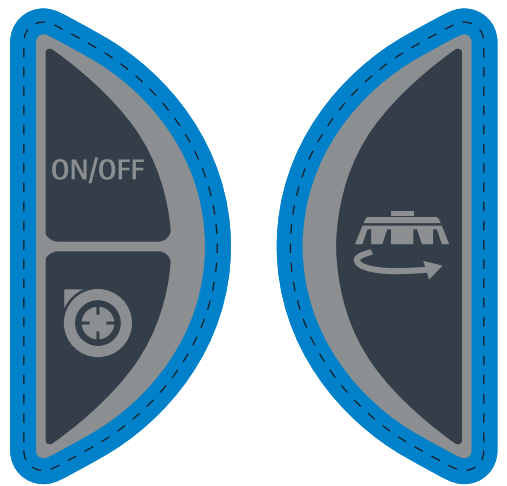

433742

433743

437703(1) label 1: ATTENZIONE, RICA/RCA, BATTERY CHARGING, CARGA DE LA BATERIA, WEDERAUFLADEN DER BATTERIEN

437703(1) label 2: ATTENZIONE, RICA/RCA, BATTERY CHARGING, CARGA DE LA BATERIA, WEDERAUFLADEN DER BATTERIEN

437703(1) label 3: Chiusura rubinetto a fine lavoro, Turn off the cock when operations are finished, etc.

437703(1) label 4: ATTENZIONE, RICA/RCA, BATTERY CHARGING, CARGA DE LA BATERIA, WEDERAUFLADEN DER BATTERIEN



437703(1) label 5: ATTENZIONE, RICA/RCA, BATTERY CHARGING, CARGA DE LA BATERIA, WEDERAUFLADEN DER BATTERIEN

437703(1) label 6: ATTENZIONE, RICA/RCA, BATTERY CHARGING, CARGA DE LA BATERIA, WEDERAUFLADEN DER BATTERIEN

437703(1) label 7: ATTENZIONE, RICA/RCA, BATTERY CHARGING, CARGA DE LA BATERIA, WEDERAUFLADEN DER BATTERIEN

437703(1) label 8: RICA/RCA, BATTERY CHARGING, CARGA DE LA BATERIA, WEDERAUFLADEN DER BATTERIEN

437703(1) label 9: ATTENZIONE, RICA/RCA, BATTERY CHARGING, CARGA DE LA BATERIA, WEDERAUFLADEN DER BATTERIEN

437703(1) label 10: ATTENZIONE, RICA/RCA, BATTERY CHARGING, CARGA DE LA BATERIA, WEDERAUFLADEN DER BATTERIEN



437703(1) label 11: Chiusura rubinetto a fine lavoro, Turn off the cock when operations are finished, etc.

437703(1) label 12: ATTENZIONE, RICA/RCA, BATTERY CHARGING, CARGA DE LA BATERIA, WEDERAUFLADEN DER BATTERIEN



FIMAP S.p.A. - Via Invalidi del Lavoro, 1 - 37059 S. Maria di Zevio - Verona - Italy
Tel. +39 045 6060411 - Fax +39 045 6060417 - E-mail: fimap@fimap.com
www.fimap.com